



OPERATOR'S MANUAL

model 7600 backhoe

THIS MANUAL INCLUDES:

SERIAL NO. 1070 and later

W600 BASIC BACKHOE

W610 - BUCKET, 9"
W611 - BUCKET, 13"
W612 - BUCKET, 16"
W613 - BUCKET, 20"
W614 - BUCKET, 24"
W615 - BUCKET, 36"

W620 - HEAVY DUTY BUCKET, 9"
W621 - HEAVY DUTY BUCKET, 13"
W622 - HEAVY DUTY BUCKET, 16"
W623 - HEAVY DUTY BUCKET, 20"
W624 - HEAVY DUTY BUCKET, 24"
W625 - HEAVY DUTY BUCKET, 36"

W601 THREE POINT MOUNT KIT
W602 PTO PUMP KIT
W604 STREET PAD KIT
W702 PTO PUMP KIT



THIS SAFETY ALERT SYMBOL IDENTIFIES
IMPORTANT SAFETY MESSAGES IN THIS MANUAL



AMERIGROUP CORPORATION

1015 CALUMET AVENUE
KIEL, WISCONSIN 53042
920-894-7063

MODEL 7600 BACKHOE Operator's Manual

TABLE OF CONTENTS

SECTION	PAGE	SECTION	PAGE
Safety	4	Hydraulic System	14
Safety Decals	6	Lubrication	15
Federal Laws and Regulations	7	Removal/Storage	16
General Operation	8	Hydraulic Trouble Shooting	17
Controls	8	Valve Repair	19
Operating The Backhoe	9	Assembly	20
Transporting The Backhoe	10	Attaching Kit Instructions	21
Placing The Stabilizers	11	Hydraulic Hook-Up	23
Filling The Bucket	12	PTO Pump and Reservoir	25
Trenching	12	Parts List	26
Backfilling	13	General Specifications	42
Service	14	Torque Chart	43
Beginning Of Season	14	Control Valve Section	44

UNDERSTAND SIGNAL WORDS

DANGER: Indicates an imminently hazardous situation which, if not avoided, will result in death or serious injury. This signal word is to be limited to the most extreme situations.

WARNING: Indicates a potentially hazardous situation which, if not avoided, could result in death or serious injury.

CAUTION: Indicates a potentially hazardous situation which, if not avoided, may result in minor or moderate injury. It may also be used to alert against unsafe practices.

IMPORTANT SAFETY PRECAUTIONS

This symbol is used to call attention to safety precautions that should be followed by the operator to avoid accidents. When you see this symbol, carefully read the message that follows and heed its advice. Failure to comply with safety precautions could result in serious bodily injury.



In addition to the design and configuration of equipment, hazard control and accident prevention are dependent upon the awareness, concern, prudence and proper training of personnel in the operation, transport, maintenance and storage of equipment. Lack of attention to safety can result in accident, personal injury, reduction of efficiency and worst of all—loss of life. Watch for safety hazards and correct deficiencies promptly. Use the following safety precautions as a general guide to safe operations when using this machine. Additional safety precautions are used throughout this manual for specific operating and maintenance procedures. Read this manual and review the safety precautions often until you know the limitations.

THE TRACTOR AND/OR LOADER (IF EQUIPPED)

1. Read the tractor and/or loader operator's manual to learn how to operate your tractor and/or loader safely. Failure to do so could result in serious injury or death and equipment damage.
2. It is recommended that tractor be equipped with Rollover Protective System (ROPS) and a seat belt be used for all loader operations.
3. Add wheel ballast or front weight for stability.
4. Move wheels to the tractor manufacturer's widest recommended settings to increase stability.
5. For better stability, use tractor with wide front axle rather than tricycle front wheels.
6. Move and turn the tractor at low speeds.
7. Stop tractor engine, place transmission in park (or neutral), engage parking brake, lower loader arms to ground, cycle all hydraulic controls to relieve pressure, allow machine moving parts to stop, remove ignition key to prevent unauthorized person from starting engine before dismounting tractor or servicing, repairing, or making adjustments to the equipment.
8. Wear personal protective equipment (PPE), such as, but not limited to, protection for eyes, ears, lungs, head, hands and feet when operating, servicing, or repairing equipment. Avoid wearing loose clothing or jewelry that may catch and entangle on equipment moving parts.

THE BACKHOE

1. DO NOT operate the backhoe unless it is rigidly attached to the tractor.
2. KNOW your controls. Read this operator's manual and the manual provided with your tractor. Learn how to stop the tractor, the engine and the backhoe quickly in an emergency.
3. PROVIDE adequate front end weight to counter-balance the backhoe at all times. 20% of the total tractor, loader and backhoe weight must be on the tractor front axle. If unsure of weight distribution, determine at a weight scale. Total vehicle weight, including backhoe and counter weights, must not exceed the ROPS certificate for gross vehicle weight.
4. BE SURE the area is clear of overhead or underground utilities or other hazards.
5. POSITION a barricade around the work area.
6. KEEP all bystanders a safe distance away.
7. DO NOT attempt to enter operator's platform of backhoe by using the stabilizers as a step.
8. OPERATE from the backhoe operator's seat only.
9. ALLOW only one person to operate the backhoe at any time.
10. DISENGAGE safety locks as shown in Figures 1 & 3 before attempting to operate the backhoe.
11. NEVER dig with the backhoe unless the stabilizers are properly set.

SAFETY PRECAUTIONS CONTINUED

12. DO NOT dig under stabilizers or tractor backhoe. Soft ground or sandy soil can cause cave-ins.
13. KEEP BUCKET away from the stabilizer area to avoid possible stabilizer damage.
14. ALWAYS swing bucket uphill to dump when on a hillside and keep loaded bucket low.
15. SET BRAKES and block wheels when operating on hills and banks to avoid dangerous runaway.
16. WATCH for overhead wires. DO NOT touch wires with any part of the backhoe.
17. NEVER allow a person to work under a raised bucket.
18. NEVER lift a person with the backhoe.
19. DO NOT use the backhoe as a battering ram. Use the backhoe only for digging.
20. ALWAYS lower the backhoe bucket and stabilizers to the ground, shut off engine, and apply the parking brake before getting off unit, or when not digging.
21. NEVER leave the tractor unattended with the engine running.
22. DO NOT attempt to raise the tractor off the ground or move the tractor forward or backward using the backhoe dipperstick or bucket.

TRANSPORTATION

1. ALWAYS engage safety locks before transporting backhoe. See Figures 1 & 3.
2. DO NOT drive the tractor near the edge of a ditch or excavation.
3. ALWAYS use accessory lights and devices when transporting on a road or highway to warn operators of other vehicles. Check your local government regulations.
4. BE SURE the SMV emblem is visible to the rear.

ADJUSTMENTS AND INSPECTION

1. CHECK pins that attach backhoe to tractor and all pivot pins for tightness several times daily. Replace any parts that are bent, broken or missing.
2. ALWAYS engage safety locks before servicing backhoe. See Figures 1 & 3.
3. DO NOT oil, grease, or adjust the backhoe while it is in motion. For greasing, see Service section for details.
4. DO NOT change any backhoe relief valve settings. They are factory set for best backhoe performance and safety.
5. PROTECT YOUR EYES - WEAR SAFETY GLASSES.
6. GUARD AGAINST INJURY when driving connecting pins or performing any repair in which particles can chip from work piece or striking tool.
7. DO NOT remove any guards on backhoe or tractor.

AVOID HIGH-PRESSURE FLUIDS

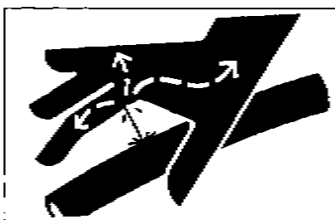

ESCAPING fluid under pressure can have sufficient force to penetrate the skin and cause serious injury. Be sure to stop engine and relieve all pressure before disconnecting lines. Be sure all connections are tight and that lines, pipes, and hoses are not damaged before applying pressure to the system. Fluid escaping from a very small hole can be almost invisible. Use a piece of cardboard or wood - not your hands - to search for suspected leaks.

SEE A DOCTOR at once if injured by escaping fluid. Serious infection or gangrene can develop if proper medical treatment is not administered immediately.

SAFETY DECALS

The safety of the operator was a prime consideration in the design of the backhoe. Proper shielding, convenient controls, simple adjustments and other safety features have been built into this implement. The following decals are located on the backhoe. Keep decals clean and replace them immediately if they are missing. Contact your dealer or Amerequip for replacements.

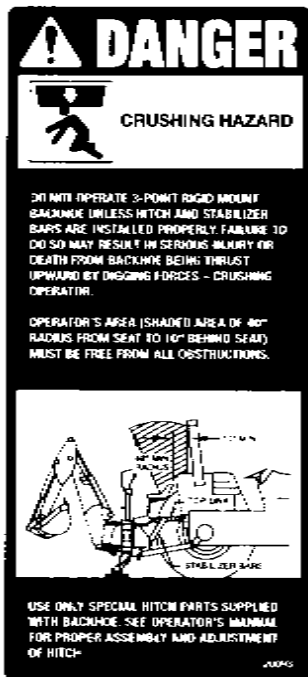

Location: Left Side of Control Tower



Location: Left Side Toe Shield Area

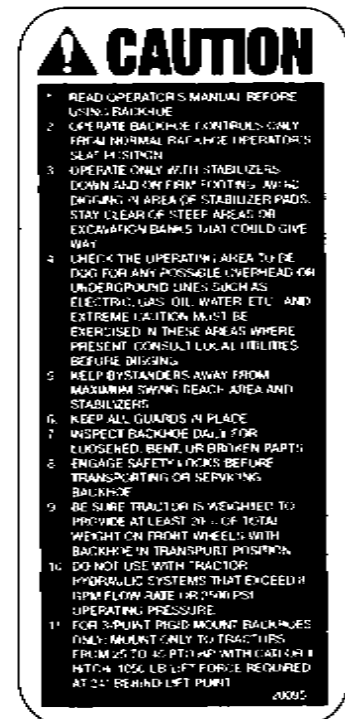

Location: Right Side of Control Tower



Location: Right Side of Control Tower

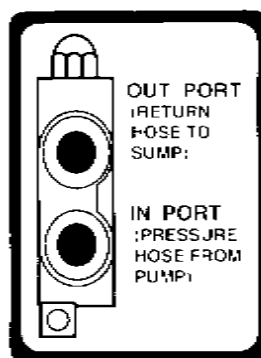

Location: Toe Shield Area

IMPORTANT FEDERAL LAWS AND REGULATIONS* CONCERNING EMPLOYERS, EMPLOYEES AND OPERATIONS.

*(This section is intended to explain in broad terms the concept and effect of the following federal laws and regulations. It is not intended as a legal interpretation of the laws and should not be considered as such).

U.S. Public Law 91-596 (The Williams-Steiger Occupational and Health Act of 1970) OSHA

This Act Seeks:

"...to assure so far as possible every working man and woman in the nation safe and healthful working conditions and to preserve our human resources..."

DUTIES

Sec. 5 (a) Each employer—

- (1) shall furnish to each of his employees employment and a place of employment which are free from recognized hazards that are causing or are likely to cause death or serious physical harm to his employees;
- (2) shall comply with occupational safety and health standards promulgated under this Act.
 - (b) Each employee shall comply with occupational safety and health standards and all rules, regulations and orders issued pursuant to this Act which are applicable to his own actions and conduct.

OSHA Regulations

Current OSHA regulations state in part: "At the time of initial assignment and at least annually thereafter, the employer shall instruct every employee in the safe operation and servicing of all equipment with which the employee is, or will be involved." These will include (but are not limited to) instructions to:

Keep all guards in place when the machine is in operation;

Permit no riders on equipment;

Stop engine, disconnect the power source, and wait for all machine movement to stop before servicing, adjusting, cleaning or unclogging the equipment, except where the machine must be running to be properly serviced or maintained, in which case the employer shall instruct employees as to all steps and procedures which are necessary to safely service or maintain the equipment.

Make sure everyone is clear of machinery before starting the engine, engaging power, or operating the machine.

EMPLOYEE TRACTOR OPERATING INSTRUCTIONS:

1. Securely fasten your seat belt if the tractor has a ROPS.
2. Where possible, avoid operating the tractor near ditches, embankments, and holes.
3. Reduce speed when turning, crossing slopes, and on rough, slick, or muddy surfaces.
4. Stay off slopes too steep for safe operation.
5. Watch where you are going, especially at row ends, on roads, and around trees.
6. Do not permit others to ride.
7. Operate the tractor smoothly - no jerky turns, starts, or stops.
8. Hitch only to the drawbar and hitch points recommended by tractor manufacturers.
9. When tractor is stopped, set brakes securely and use park lock if available.

Child Labor Under 16 Years Old

Some regulations specify that no one under the age of 16 may operate power machinery. It is your responsibility to know what these regulations are in your own area or situation. (Refer to U.S. Dept. of Labor, Employment Standard Administration, Wage & Home Division, Child Labor Bulletin #102.)

GENERAL OPERATION

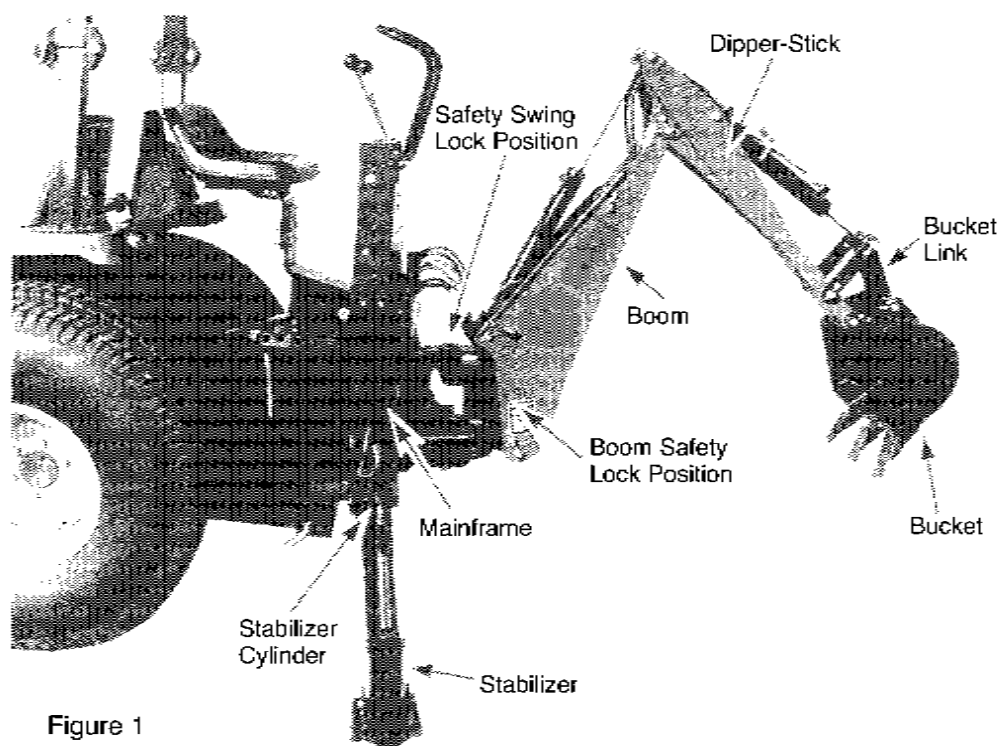

Figure 1

CAUTION

To avoid the possible injury, observe the following safety rules **BEFORE OPERATING** the backhoe:

1. **BE SURE** area is clear of underground utilities or other hazards.
2. **POSITION** barricade around work area.
3. **PROVIDE** adequate front end weight to counter-balance tractor at all times. 20% of the total tractor, loader and backhoe weight must be on the tractor front axle.
4. **Keep bystanders** a safe distance away.

DIRECTIONS: The terms right, left, front and back shall be determined from the position of the operator when seated in the operating position on the backhoe.

ENGINE SPEED

The speed at which the backhoe operates is partially dependent on engine RPM. Use a moderate engine speed to start and increase it as your experience permits. Refer to "DIMENSIONS AND SPECIFICATIONS" on Page 42 for hydraulic flow volume requirements. When powering from tractor systems with higher output, reduce engine RPM to obtain acceptable backhoe operating speed.

Figure 2 Control Handles

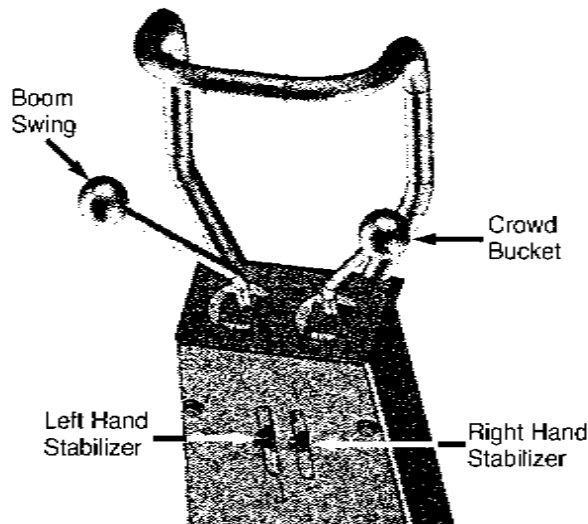

CONTROLS

The backhoe has two major control levers plus the stabilizer control levers. These controls are located on the control panel directly ahead of the operator. See Figure 2. The following is a list of the controls, with the function of each, reading from left to right.

1. Boom/Swing: Push lever forward, the boom moves down, away from the operator. Pull lever back, the boom moves up, toward the operator.

The Boom/Swing Control Lever has an added "float" function. A detent or stop should be felt when the lever is pushed forward to move the boom down. Pushing the lever forward more will overcome the detent and cause the boom to float, or move down or up freely, depending on the forces acting on it. When the lever is released it should return to the center, neutral position.

Move lever to the left, the backhoe swings to the left. Move lever to the right, the backhoe swings to the right.

By moving the lever to one of the intermediate positions, the boom can be swung left or right at the same it is being raised or lowered, performing the two operations simultaneously.

SWING LEFT AND LOWER the boom by moving the control lever forward and to the left.

SWING LEFT AND RAISE the boom by moving the control lever back and to the left.

Figure 3
Safety Locks

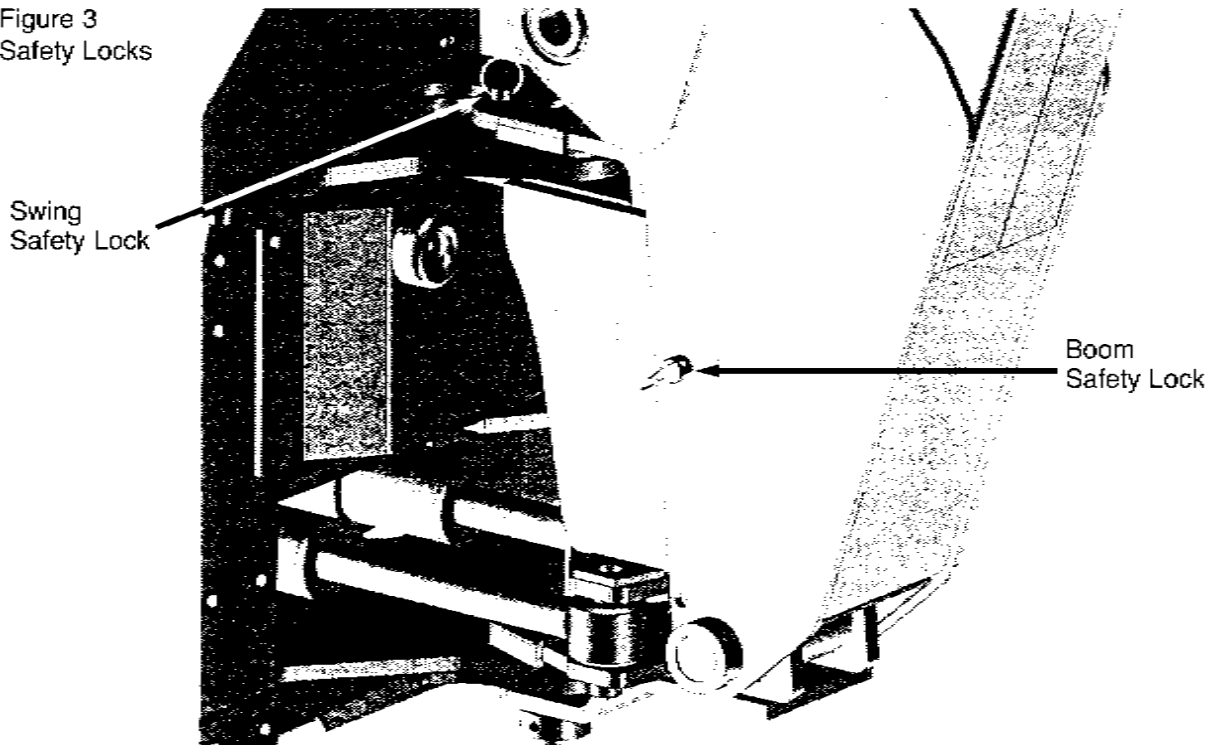

SWING RIGHT AND LOWER the boom by moving the lever forward and to the right.

SWING RIGHT AND RAISE the boom by moving the lever back and to the right.

2. Left Hand Stabilizer: Push lever downward, the LH stabilizer lowers. Pull lever upward, the LH stabilizer raises.

3. Right Hand Stabilizer: Push lever downward, the RH stabilizer lowers. Pull lever upward, the RH stabilizer raises.

4. Crowd/Bucket: Push lever forward, the dipperstick moves out, away from the operator. Pull lever back, the dipperstick moves in, toward the operator.

Move lever to left, the bucket curls in. Move lever to right, the bucket extends out.

By moving the lever to one of the intermediate positions, the dipperstick can be extended or retracted at the same time the bucket is being loaded or dumped.

EXTEND AND LOAD the bucket by moving the lever forward and to the left.

RETRACT AND LOAD the bucket by moving the lever back and to the left.

EXTEND AND DUMP the bucket by moving the lever forward and to the right.

RETRACT AND DUMP the bucket by moving the lever back and to the right.

The two operations of the boom lever, combined with the two operations performed by the bucket and dipperstick control lever, provide four simultaneous oper-

ations from the two levers, keeping cycle time to a minimum.

In general, the direction of movement of a control lever corresponds to the movement of the operating member.

OPERATING THE BACKHOE

⚠ CAUTION ⚠

To avoid possible injury, observe the following safety rules **WHEN OPERATING** the backhoe.

1. DISENGAGE safety locks as shown in Figure 3 before attempting to operate the backhoe. Store lockpins in holes provided in operator platform.

2. OPERATE from the backhoe operator's seat only.

3. LOWER the stabilizers until the rear of the tractor is totally supported by them. **NOTE:** Rear tires should **not** come up off of the ground. See diagram on Page 11.

4. DO NOT dig near the stabilizers.

5. DO NOT touch overhead wires with any part of the backhoe.

6. DO NOT attempt to raise the tractor off the ground or move the tractor forward or backward using the backhoe dipperstick or bucket.

7. DO NOT lose stability by swinging the bucket downhill when positioned on a slope.

8. DO NOT lower the backhoe boom using the "float" function. It will freefall, and could result in injury to bystanders or damage to the backhoe.

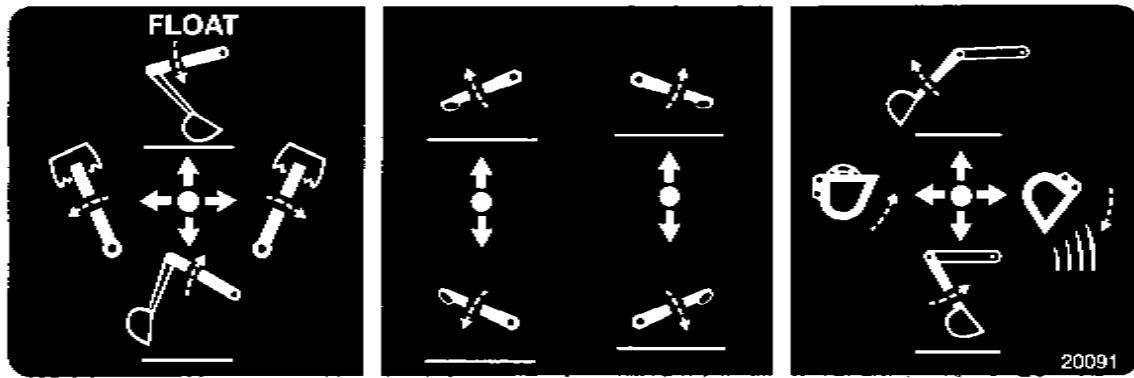

Location: Back Of Control Panel

It is not difficult to become an efficient operator. Control lever operating decal is located on back of the control panel. Study this decal. It will assist you in becoming familiar with the controls.

Smooth, light handling of the controls will result in the most efficient backhoe operation.

Operate the backhoe control levers to become familiar with their speed and movements. The engine speed and the size of the hydraulic system will determine the speed of cylinder operation. When powering from tractor systems with higher output than required, reduce engine RPM to obtain acceptable backhoe operating speed.

Swing the boom several times to practice controlling the speed of swing. Do not operate the swing more than 45° each way for the first few times, then gradually increase the arc.

IMPORTANT: To avoid damage to the backhoe, do not slam swing unit into the rubber bumpers.

The boom "float" function may be used during digging to eliminate down pressure when cleaning the bottom of a trench. The primary purpose of the boom "float" function is to protect the operator from serious injury in the event that the backhoe or tractor hitch would fail.

Best results are obtained by digging near the center of the swing arc so material can be dumped on either side.

As the operator becomes more familiar with the operation of the backhoe, it will be common practice to operate two controls at one time. For example; with the bucket extended and the dipperstick extended, the lift control and crowd control can be operated together to bring the bucket toward the operator with down pressure on it. As the dipperstick approaches the operator, the crowd and bucket controls can be operated to close the bucket and trap the material. At the end of the stroke, the lift and crowd controls are operated to move the load up and away from the operator to save time in clearing the excavation.

This dual operation of controls will speed and simplify the digging operation. Normally the two or more movements will not be equal or even simultaneous, but as the pressure within the cylinders changes, and the resistance on an operating member of the hoe lessens, it will begin to move. It is balancing the force of one member against the other.

NOTE: Actuating the bucket is the key to powerful digging. Operating the crowd and bucket controls simultaneously will insure a full bucket and prevent waste motion and time.

TRANSPORTING THE BACKHOE

IMPORTANT: To prevent serious damage to the tractor, read and follow the instructions on the following decal:

IMPORTANT

IMPROPER TRANSPORTING METHODS CAN CAUSE SERIOUS DAMAGE TO TRACTOR.

- ENGAGE BOTH SAFETY LOCKS WHEN TRANSPORTING BACKHOE.
- TRAVEL SLOWLY OVER ROUGH TERRAIN.
- WHEN TRANSPORTING ON TRUCK OR TRAILER, LOWER BACKHOE BOOM SO BUCKET RESTS FIRMLY ON BED. APPLY RESTRAINTS TO TRACTOR, NOT TO BACKHOE OR BACKHOE ATTACHING KIT.

Location: Right Side of Boom

⚠ CAUTION ⚠

To avoid possible injury, observe the following safety rules when transporting the backhoe:

1. ALWAYS engage safety locks as shown on Figs. 1 and 3 when transporting backhoe.
2. TRAVEL SLOWLY over rough terrain, on hillsides, and around curves to prevent tipping.
3. DO NOT drive the tractor near the edge of a ditch or excavation.

4. USE accessory lights and SMV emblem when traveling on highways.

Before leaving backhoe operator's seat, position the backhoe for transport by raising boom, crowding dipperstick in, swinging to center and raising the stabilizers. ALWAYS engage safety locks as shown in Figs. 1 and 3 when transporting.

When transporting for long distances, periodically examine the backhoe and raise stabilizers and bucket back up to the full transport height. It is normal for the backhoe to slowly settle while being transported.

WHEN TRANSPORTING

Note:

Bucket should be lowered to bed when possible.

⚠ CAUTION ⚠

DO NOT CHAIN BACKHOE DOWN IN ORDER TO SECURE CRAWLER TO TRAILER

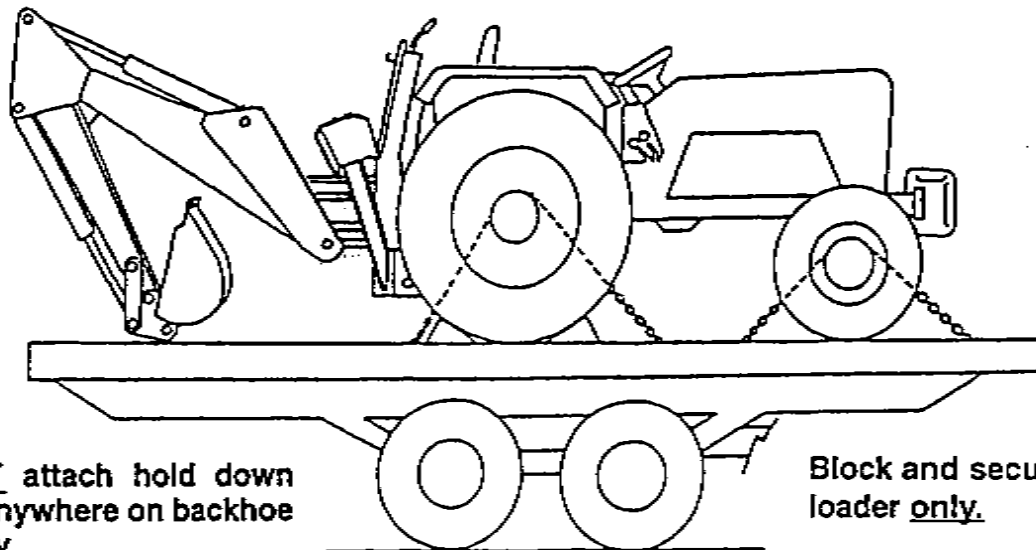

DO NOT attach hold down chains anywhere on backhoe assembly.

Block and secure loader only.

PLACING THE STABILIZERS

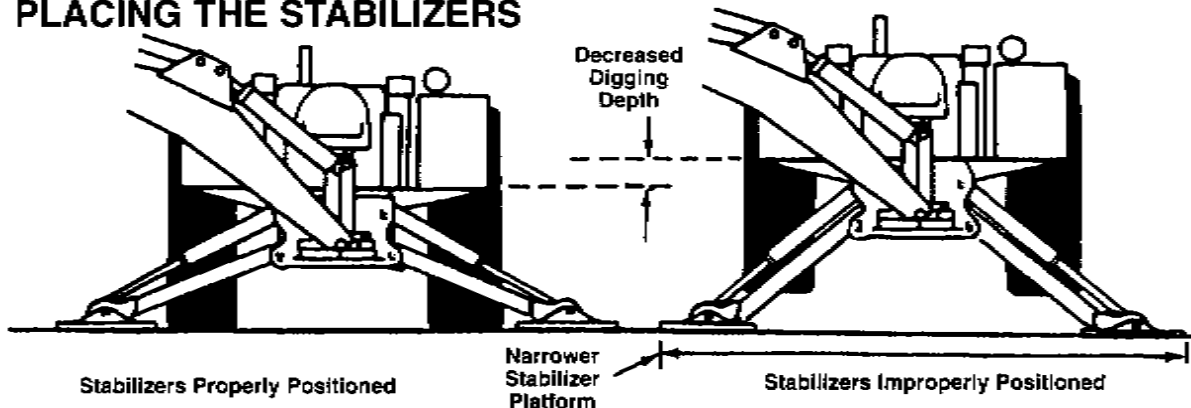

Set the stabilizers to remove weight from the rear wheels. The wheels are to remain touching the ground as this provides for the widest stabilizer stance and the lowest center of gravity. Raising the wheels off the ground will not only reduce stability and digging depth, but will impair performance and impose unnecessary stress on the unit.

General Operations

FILLING THE BUCKET

Control the bucket attitude throughout the digging cycle to keep teeth at the proper angle for best penetration. This will minimize dragging and scraping the bucket through the ground.

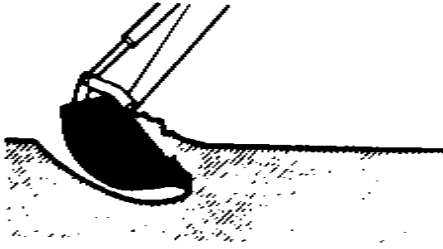

When digging in hard-packed soil, bucket penetration can be increased by applying down pressure with the boom while crowding in and curling the bucket. If the crowd action "stalls" it may be necessary to apply lift occasionally during the digging cycle to correct the bucket depth.

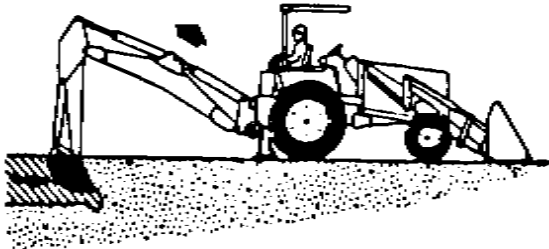

To obtain a cleaner trench and avoid the buildup of material directly in front of the backhoe, crowd out and completely curl the bucket while starting to lift it from the excavation. In this way, excess material will fall back into the excavation.

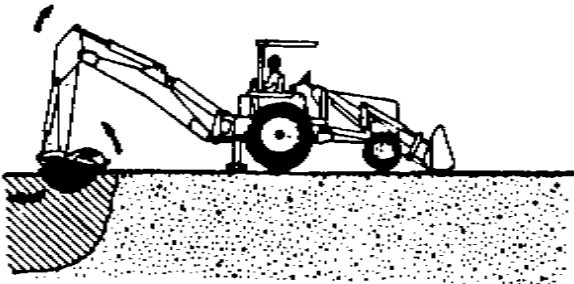

DUMPING THE BUCKET

To dump the bucket at the end of the digging cycle, lift the bucket clear of the trench while crowding it out and swinging it to the spoil pile.

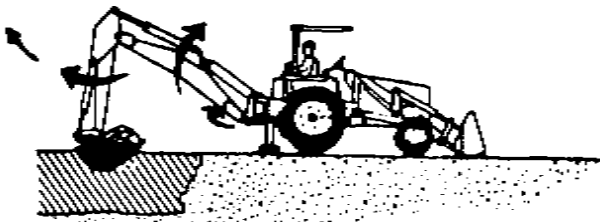

As the pile is approached, dump the bucket. When the bucket is empty, the dipperstick and bucket are in position to resume digging upon return to the trench.

IMPORTANT: Avoid constant jarring or hammering-type contact between the spoil pile and the loaded bucket, as this may cause premature wear to the backhoe pins and bushings.

TRENCHING BETWEEN A BUILDING AND OPEN EXCAVATIONS

Start the trench at the building. Trench out halfway to the excavation. Then start trenching from the excavation to the first trench. Dig toward the first trench until there is just enough room to move the unit out between the two trenches.

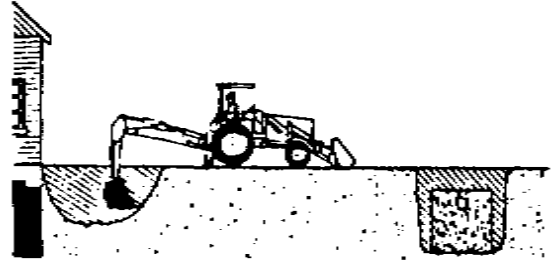

Position the unit so the backhoe swing post is over the centerline of the trench connection. Dig with the backhoe at extreme swing positions, and in as close to the stabilizers as possible. Pile the spoil on the opposite side of the trenches.

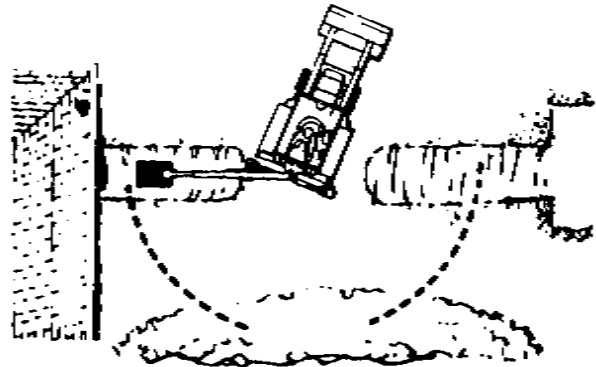

Position the unit forward with the lift and crowd levers so the two trenches can be connected. Pile the spoil on the opposite side of the trench.

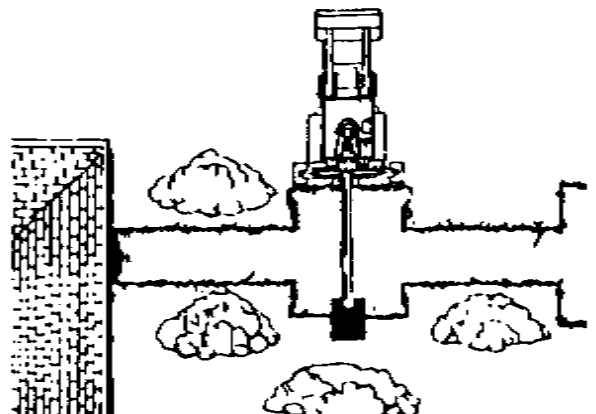

General Operations

SIDE SLOPE EXCAVATING OR TRENCHING

Dig with the backhoe uphill whenever possible.

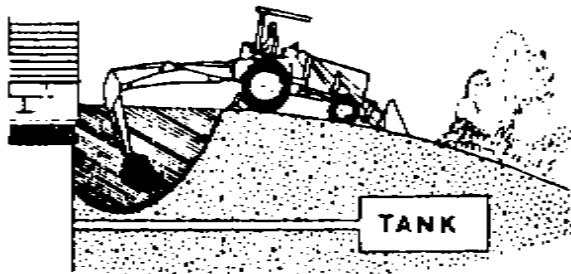

Level the backhoe on slopes with the stabilizers to dig plumb trenches, or use the backhoe or loader to cut a level slot for the uphill wheel and stabilizer. Pile the spoil from the slot on the low side.

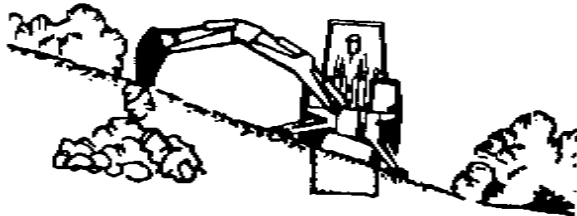

When on the side of a steep slope, cut a level surface along the uphill side of the trench with the loader.

Pile the spoil of the cut downhill. When digging, pile the spoil of the trench uphill.

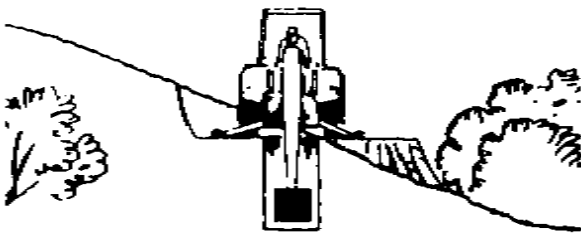

Dig field trenched progressively. As soon as one trench is completed, have the workmen lay the tile. Start the next trench, using the spoil to fill the previous trench.



MISCELLANEOUS

When finishing straight walls or bellholes in sandy soil, use a platform under the rear tires and the stabilizers. The platform distributes the load over a larger area and lessens the possibility of a cave-in. The platform also tends to keep the unit from creeping rearward if hard digging is encountered.

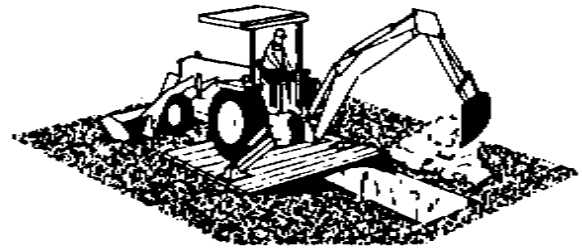

FINISHING STRAIGHT WALLS

Finish the far wall by crowding out while forcing the bucket down from the boom. Actuate the bucket (curl out) to keep the bottom of the bucket vertical.

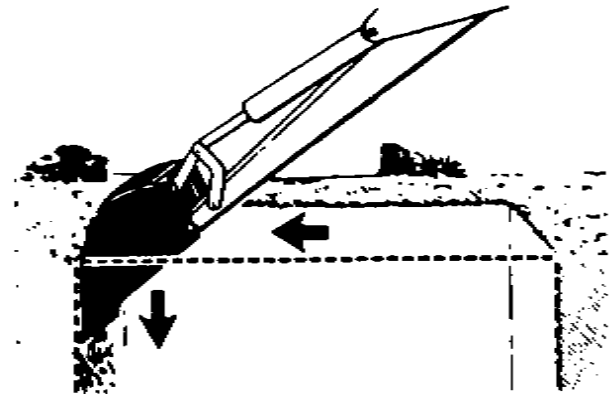

To finish the near wall, lift up and crowd in. Keep the edges of the bucket horizontal.

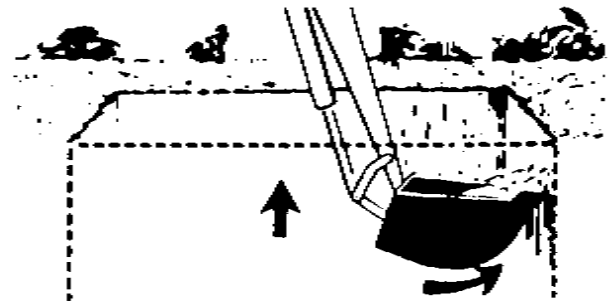

BACKFILLING

Backfill by lifting the bucket over the spoil pile and then crowding in. Pull both the crowd and lift levers for smooth, even backfilling.

IMPORTANT: Do not backfill by using the swing circuit and dragging the bucket sideways. Doing so can cause damage to the dipperstick boom swing cylinders or mainframe.

SERVICE

⚠ CAUTION ⚠

To avoid possible injury, observe the following safety rules **WHEN SERVICING** the backhoe:

1. ENGAGE safety locks as shown in Figures 1 & 3 before servicing the backhoe.
2. DO NOT oil, grease or adjust the backhoe while it is in motion.
3. DO NOT change any backhoe relief valve settings. They are factory set for best performance and safety.

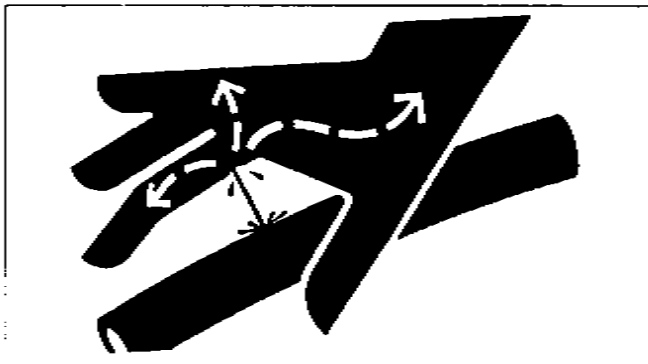

4. ESCAPING FLUID under pressure can have sufficient force to penetrate the skin and cause serious injury. Be sure to relieve all pressure before disconnecting lines. Be sure all connections are tight and that lines, pipes and hoses are not damaged before applying pressure to the system.

5. FLUID ESCAPING from a very small hole can be almost invisible. Use a small piece of cardboard or wood - not your hands - to search for suspected leaks.

6. SEE A DOCTOR AT ONCE if injured by escaping fluid. Serious infection or gangrene can develop if proper medical treatment is not administered immediately.

7. PROTECT YOUR EYES - Wear safety glasses. Guard against injury when driving connecting pins or performing any repair in which particles can chip from work piece or striking tool.

BEGINNING OF SEASON

Remove all protective covering.

Check hydraulic hoses for deterioration and replace, if necessary.

Lubricate all grease fittings and oil handle linkage.

Check hydraulic system for loss of fluid and, if necessary, fill to proper level.

Tighten all loose bolts, nuts and setscrews.

Inspect bucket teeth and, if necessary, sharpen or replace them.

Operate the backhoe slowly for a short time before placing the unit under full load.

HYDRAULIC SYSTEM

Bleeding Backhoe Hydraulic System

If the hydraulic hoses have been disconnected from the backhoe or tractor, all trapped air must be removed after the hoses are connected. Start tractor engine and operate backhoe through all movements fully, several times, to purge the system of air.

Hydraulic System Hoses

Oil leaks in the pressure side of the system can be located by carefully inspecting the external area of the hoses and fittings.

Check the return side of the system for leaks by examining the oil in the reservoir. If air is being drawn into the system, the oil will contain air bubbles and appear to foam.

When tightening connections, always use two wrenches.

IMPORTANT: Do not over-tighten fittings. Make them just tight enough to eliminate leaks.

NEVER use teflon tape on pipe thread fittings. Always use a paste-type sealer.

Hoses on any backhoe are very severely worked and will fail in time. Examine them regularly and replace any that show signs of failure. Pay careful attention to the routing of hoses so they can move fully and freely without kinking, and cannot be pinched or cut by any part of the backhoe.

Hydraulic System Reservoir

On PTO pump contained systems, maintain the reservoir oil at the proper level by looking at the dipstick. The dipstick/breather cap is located directly behind the right hand foot pad on the backhoe. When checking oil level, the backhoe should be extended to full reach with the bucket rolled back and resting on the ground. All cylinders are retracted except for the boom cylinder. Do not overfill; oil may be forced out of the breather cap.

Fill with:

SAE 10W40 engine oil with API "SF/SG" classification in northern climates.

SAE 40W engine oil with API "SF/SG" classification in southern climates.

Change oil every 200 hours or more often if necessary.

If the tractor system supplies the hydraulic power, service according to the tractor instruction manual.

Bucket Tooth Points

Figure 5

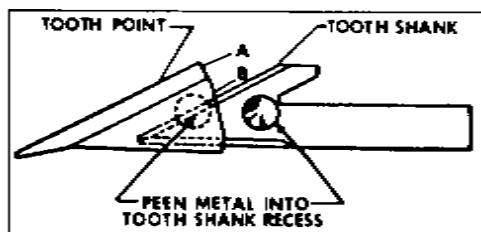

The bucket tooth points are self-sharpening and will require little attention; however, these points on the bucket shanks can be replaced when they become badly worn or broken.

A tooth point can be removed from the welded tooth shank by hammering at "A" (Figure 5) on the tooth point or by driving a chisel at "B", just between the tooth point box section and the tooth shank. Install the new point and anchor it to the shank by peening at the location shown.

If a tooth shank breaks off, becomes damaged or lost so that it cannot hold a tooth point, a new shank should be welded to the bucket in its place.

Tightening Nuts and Bolts

Periodically, check to be sure all bolts and nuts are tight. See torque chart, page 43.

Check all pivot pins for cotter pins, washers and retainers; if missing, replace.

LUBRICATION

Economical and efficient operation of the backhoe is dependent upon regular and proper lubrication of all moving parts with a quality lubricant.

All parts provided with grease fittings should be lubricated with a good quality chassis lube type grease. If any grease fittings are missing, replace them immediately. Clean all fittings thoroughly before using grease gun.

Lubricate all grease fittings at least twice daily, once at the beginning of operation and again approximately halfway through the work day.

Lower stabilizers to the ground, extend dipperstick and bucket and lower boom so bucket rests on the ground as shown in Figure 6. Refer to these illustrations for the location of all grease fittings.

**IMPORTANT: Before greasing boom to swing frame pivot (*) shown in Figure 6, raise boom and install boom safety lock pin shown in Figure 1.*

The following locations should be oiled with SAE30 oil:

- A. Stabilizer Pivot Pins
- B. Control Handle Linkage
- C. Seat Bracket Pivot

IMPORTANT: Avoid excessive greasing. Dirt collects on exposed grease and increases wear greatly. After greasing, wipe off excessive grease from fittings.

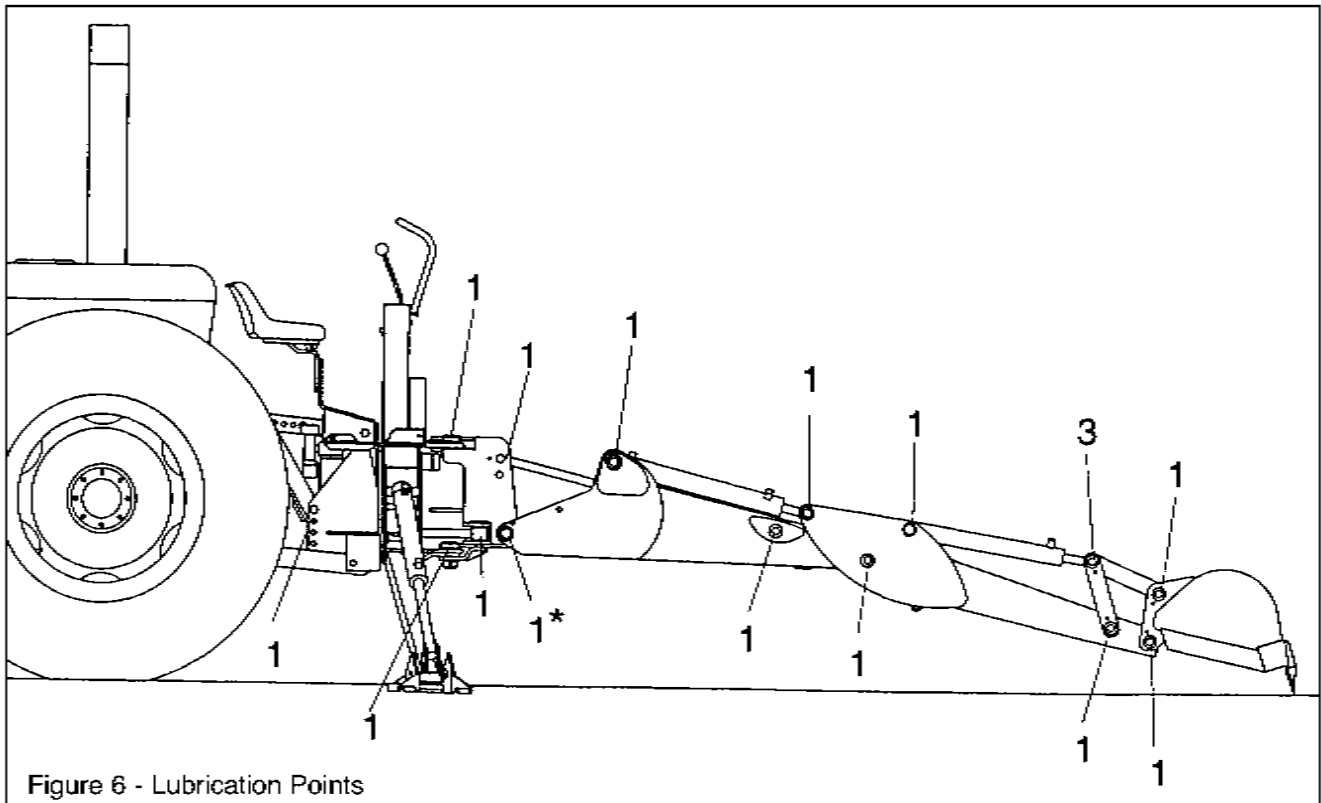
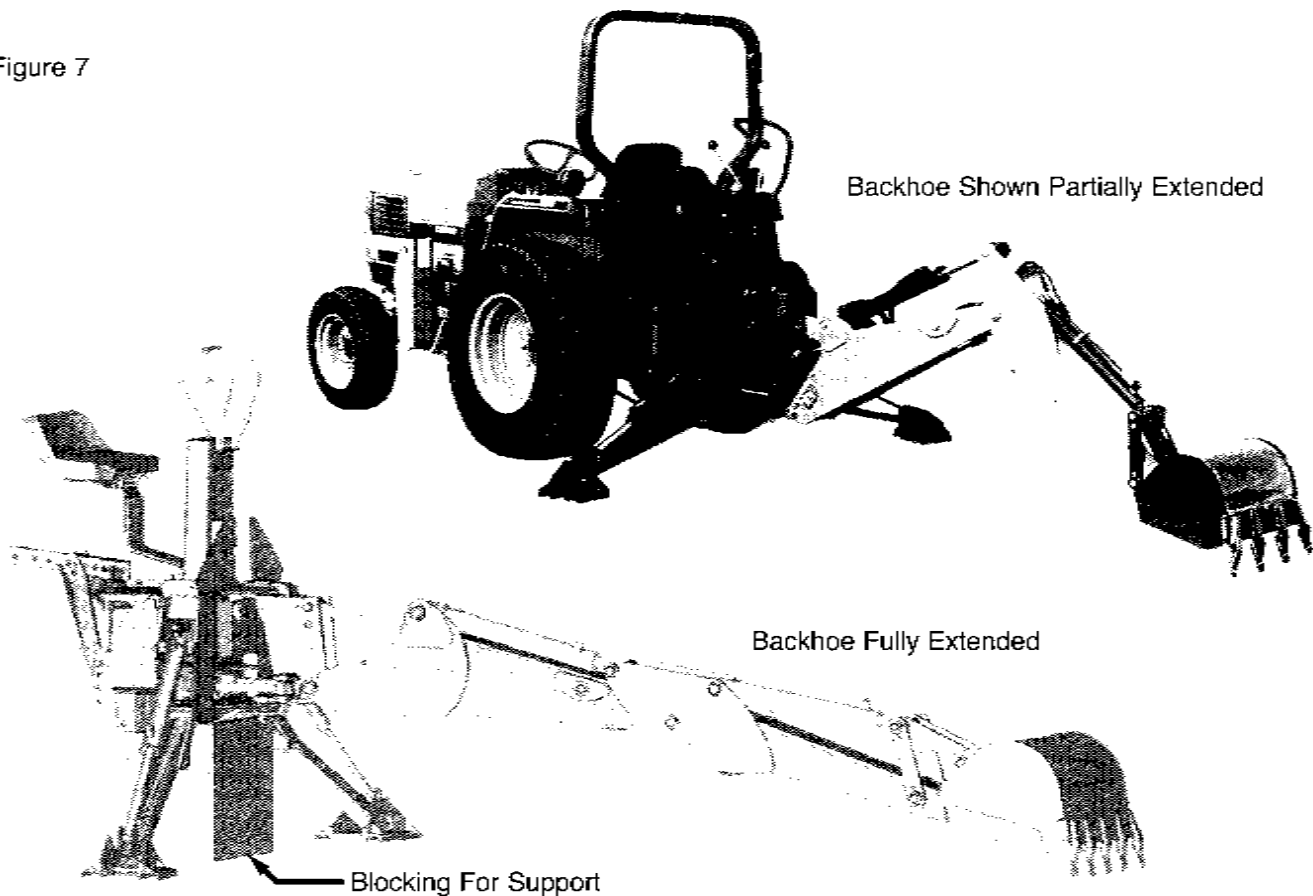

Figure 6 - Lubrication Points

REMOVAL FROM TRACTOR - STORAGE

Figure 7



The backhoe is self-assisting during the installation and removal procedures. For removal and storage, follow these steps:

1. Install the swing safety lock pin as shown in Figures 1 and 3.
 2. Stretch out the boom, dipper arm and bucket as shown in Figure 7. Lower the bucket to the ground so that it rests there solidly.
 3. Raise the backhoe operator's seat until it's in the raised position.
 4. Place suitable blocking under the backhoe frame to support it adequately as indicated in Figure 7.
 5. Detach the backhoe from the tractor mechanically only, not hydraulically at this point. Move the tractor a few inches away from the backhoe.
- Note: To facilitate this procedure, the backhoe can still be hydraulically moved, raised or lowered, to release the connection points of the carrying forces.*
6. Gently lower the backhoe onto the blocking as indicated in Figure 7. Leave the stabilizers outstretched and firmly in contact with the ground for added stability.
 7. The hydraulic system can now be disconnected.

⚠ CAUTION ⚠

Make sure tractor PTO is disengaged and engine shut off before disconnecting pump or hydraulic lines.

- a. On PTO pump self-contained systems the pump should be removed from the PTO shaft. The hydraulic system should always remain complete. No hoses or oil lines should be disconnected during correct removal and storage procedure.
- b. On systems that tap into the tractor for hydraulic power, these lines can be disconnected now.

IMPORTANT: Be sure to mark the lines to prevent mix-up, during hook-up, when the hoe is again attached to the tractor.

Be sure to cap the ends of the lines to keep clean while in storage.

8. Now slowly drive the tractor forward and away from the backhoe. Be careful that all parts clear each other during separation.
9. Refer to the installation instructions for the attaching kit. This will help with the removal and reattaching.
10. For long term storage, coat exposed lift, swing and stabilizer cylinder rods with grease.
11. Lubricate all grease fittings and oil stabilizer pivot pins, and complete handle linkage.

Stabilizer Pads

The backhoe is supplied with flip-over stabilizer pads as standard equipment. They are suitable for most backhoe work and generally are all that is ever required. However, street pad kits are available as options. This kit bolts to the standard pads and increase the versatility of the backhoe.

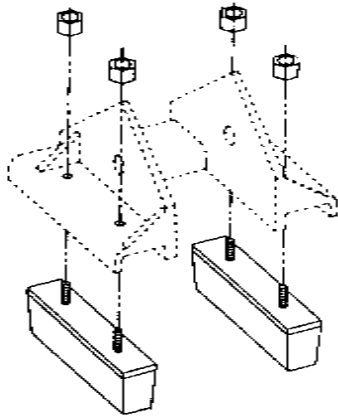

HYDRAULIC TROUBLE SHOOTING

The trouble shooting material presented in this section is offered as a guide to diagnosing probable causes and remedies for general operational problems. Match your problem with the typical problem examples given, and note the numbers given for the possible cause. These numbers correspond with the possible cause and correction paragraphs that follow.

NOTE: When using the following chart, if it is decided that an overhaul of components or pressure adjustments are necessary to correct malfunctioning, it is recommended that your dealer make these repairs. He is equipped to do this work.



Escaping hydraulic / diesel fluid under pressure can penetrate the skin causing serious injury.

Do not use your hand to check for leaks. Use a piece of cardboard or paper to check for leaks.

Stop engine and relieve pressure before connecting or disconnecting lines.

Tighten all connections before starting engine or pressurizing lines.

If any liquid is injected into the skin, obtain medical attention immediately or gangrene may result.

Problems and Possible Causes

- A. Machine fails to operate when started initially - 1, 2, 5, 7, 16, 24
- B. Machine loses power after operating satisfactorily initially - 1, 8, 10, 14, 16, 24
- C. Loss of power in lift or crowd cylinder, but other cylinders function properly - 23, 25, 30

Problems and Possible Causes, Continued

- D. Loss of power in any one cylinder including lift and crowd - 8, 9, 10, 11, 12, 13, 23, 25, 26
- E. Loss of power in swing cylinders, but other cylinders functioning properly - 8, 9, 10, 11, 12, 13, 23, 24, 26
- F. Maximum swing action cannot be obtained - 12, 15
- G. Slow operation of machine (lack of power) all cylinders - 1, 4, 6, 14, 16, 24
- H. Spongy or jerking action of cylinders and/or noisy operation - 1, 3, 4, 5
- I. Lift, crowd or bucket cylinders drop under load when control spools shifted from neutral - 28, 30
- J. Load drops or settles - 8, 10, 13, 26, 28
- K. Leaky cylinders - 10, 11, 12, 13
- L. Leaky valve - 8, 16, 17, 29
- M. Sticky valve spool - 17, 20, 21, 22
- N. Unable to push valve spool in - 17, 18, 20, 21, 22
- O. Spring centered spools do not return to neutral - 17, 18, 19, 20, 21, 22

Causes and Corrections

- 1. Low oil supply in reservoir - fill to proper level.
- 2. No oil supply to machine - oil is not being diverted from the prime mover hydraulic system. Be sure that the proper controls are actuated on the prime mover.
- 3. Air in system - bleed all circuits of air by operating machine at maximum oil flow and through full movements.
- 4. Oil viscosity too heavy, or oil is not at operating temperature - use recommended hydraulic fluid. Run machine until oil reaches operating temperature.
- 5. Pump not running - check pump drive to be sure it is engaged.
- 6. Insufficient pumping - advance engine throttle.
- 7. Improper hose connection - **IMPORTANT: Be sure inlet and return hoses are hooked up correctly. Improper hook-up will result in damage to the backhoe valve.**
- 8. Loose oil line connections, leaks in line or broken lines - tighten all hose connections and replace any damaged O-rings at leaking O-ring fittings. Check and replace any damaged hoses and lines.
- 9. Restrictions in oil lines - check and replace any damaged hoses and lines. Check for pinched hoses.
- 10. Oil is bypassing cylinder piston, scored piston, worn piston packing, or defective piston assembly - replace or rebuild the cylinder; replace damaged parts.
- 11. Scored piston rods and worn rod guides in cylinder - replace or rebuild the cylinder; replace damaged parts.

Continued

Causes and Corrections, Continued

12. Bent piston rod in cylinder - replace or rebuild the cylinder; replace damaged parts.
13. Worn or damaged rod seals on cylinder; external leaks - repack cylinder. Rebuild cylinder, replacing damaged parts as necessary.
14. Diverter valve on prime mover leaking externally or bypassing oil internally through valve to reservoir - diverter valve may need rebuilding or replacing.
15. Something jamming the swing linkage - remove interference.
16. Excessive back pressure - relieve condition. May be restriction from outlet to reservoir.
17. Paint on valve spool; sticking valve spool or scored valve spool - clean valve spool. Binding is usually caused from an over tightened plug, mounting bolt, fitting in valve body or tie rod bolt. If a plug or fitting in the valve body is leaking, do not over tighten in an effort to stop leak. This will distort body casting and cause spools to bind. Instead, the plug and fitting should be removed from valve body and be reconnected, using a new O-ring. Do not apply excessive pressure on mounting bolts. The rods should be torqued to 20 ft./lbs. Never force spool, if binding occurs see item 30 at the end.
18. Oil leakage past spool seal into spool cap - remove cap. If it contains oil replace spool seal O-rings. Check O-ring retainer to be sure it is flat. If it has been "belled" check for restriction from outlet to reservoir of valve which would cause excessive back pressure. See item 30 at the end and item 9.
19. Broken return springs - replace springs, see item 30 at the end and Figure 11.
20. Bent spool - replace with new spool section. See item 30 at the end.
21. Foreign particles - clean system and valve.
22. Misalignment of control handle linkage - check linkage for binding condition.
23. Spool not moved to full stroke - check travel, should be 5/16" either way, or a total of 5/8". See item 30 at the end.
24. Relief valve setting in backhoe control valve too low or defective - relief pressure will have to be checked and corrections made. Backhoe system pressure is 2100 psi. Relief valve may need cleaning and overhauling, or entire cartridge must be replaced. See item 30 at the end.
25. Overload relief valve in the control valve stuck open or malfunctioning - clean relief carefully but do not disturb its pressure setting as it cannot be field calibrated, or replace cartridge. See item 30 at the end.
26. Worn control valve - replace the control valve.
27. Check poppet in the control valve not holding - clean check poppet(s) carefully, being sure that it moves freely with good spring action and seats properly or replace. See item 30 at the end.
28. Damaged or worn spool seals - replace spool end seals, see item 30 at the end.
29. Ball in anti-cavitation check valve is stuck or not seating properly - clean anti-cavitation valve carefully, being sure that checks move freely and seat properly, or replace cartridge. See item 30 next.
30. Problems involving the control valve proper:

This valve is a precision device and is not intended for any extensive field adjustment or repair. Field replacement parts are limited to seal kits, cartridges, valve sections and tie rods.

Replacement of these parts, the opening of check cavities and certain relief valve cavities to examine for trapped dirt, or the resetting of the main relief valve with the use of good pressure gauge, should be referred to qualified service personnel.

Dirt and shreds of packing material are the usual causes of valve malfunction. Be sure the reservoir oil supply is kept clean and only factory supplied packings are used in cylinder repair. Everything must be clean and free of dirt during the oil line removal and replacement, and during any cylinder work.

Pages 19 and 20, Valve Repair-Disassembly, explain the procedure to follow for valve repair.

The inclusion of this information and its use does not imply that the warranty will remain effective on the valve if it is tampered with during the warranty period.

VALVE REPAIR - DISASSEMBLY

Figure 8

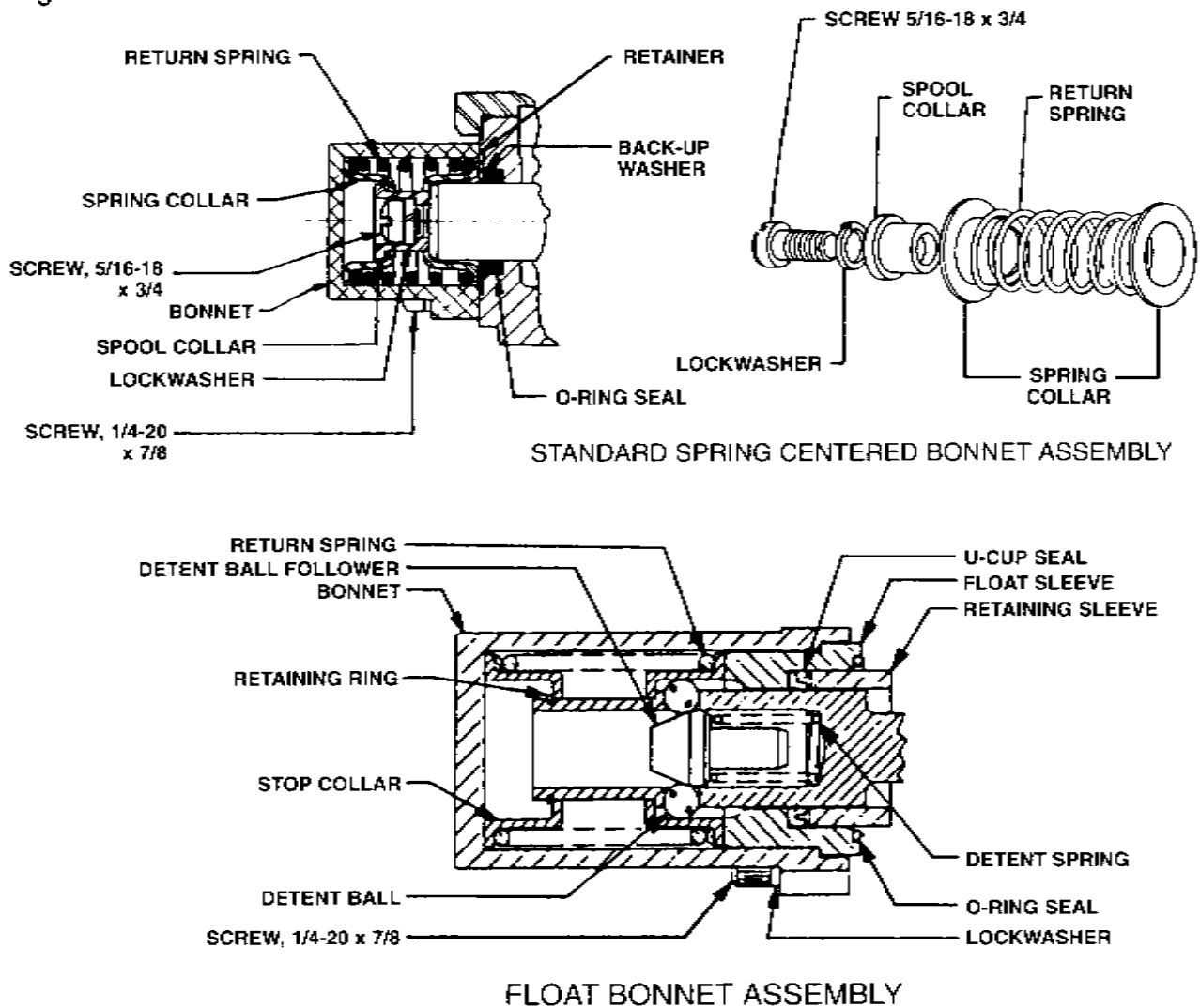

Replace Center Section Assemblies:

Note: For the purpose of these instructions we will consider the section containing the MAIN RELIEF VALVE as the left side of the valve.

1. Remove control valve from the backhoe.
2. Thoroughly clean the exterior of the valve before beginning disassembly procedures.
3. Since the valve will be assembled in the same order, each section should be marked numerically so that they can be reassembled in the same sequence.
4. Mount the valve vertically in a vise to facilitate disassembly and assembly.
5. Remove the 3 tie rod nuts from the right end section, using a thin-wall socket.
6. Valve sections can now be removed by sliding the sections along the tie rods.

7. Thoroughly clean the O-ring counterbores and the ground surfaces of each section. Place O-ring seals, ordered as a kit, in proper counterbores. For better sealing it is recommended that all O-rings, used in the counterbores, are replaced with new parts.

8. Replace the sections on tie rods with the O-ring counterbores facing the right end of the valve. Be careful replacing the sections so that the section O-rings are not moved from the counterbores.

9. When all sections are assembled on the tie rods, tighten the tie rod nuts equally to 20 ft. lbs. torque, NO MORE - NO LESS, or spools may bind and stick.

Replacing Spool Seals:

Note: For the purpose of these instructions we will consider the control handle side of the valve as the FRONT, and the opposite side as the BACK.

1. Remove control valve from the backhoe.
2. Thoroughly clean the exterior of the valve before beginning disassembly procedures.

3. At the **BACK** of the valve remove all bonnet assembly parts which are connected to the spool. Keep parts in the order of disassembly. See Figure 8 for the parts involved in the make-up of the bonnet assembly.

IMPORTANT: DO NOT remove the spool from the valve. The seals can be replaced externally. Prevent spools from turning or moving by inserting a screw driver through the clevis slot, or by running a rod through the pin hole and using the rod as a handle. **DO NOT** hold the spool with a wrench. This will destroy the finish.

4. At the **BACK** of the valve, remove seal retainer, back-up washer, and spool O-ring seal, or retaining sleeve, bonnet O-ring seal and spool U-cup seal.

5. Thoroughly clean counterbores.

6. Install new seals:

A. Spring-Centered Bonnet Assembly Only:

Lightly oil new O-ring seal. Slide O-ring seal over

valve spool and insert in seal counterbore. Replace back-up washer and seal retainer.

B. Float Bonnet Assembly Only:

Replace retaining sleeve on valve spool. Lightly oil new U-cup seal. Slide U-cup seal over valve spool being careful to orient seal as shown in Figure 8. Install new O-ring seal in bonnet counterbore.

7. At the **BACK** of the valve replace bonnet assembly parts, reversing the order in which they were disassembled in step 3. Use 12 ft. lbs. torque to tighten assembly screw on spring centered bonnet assembly.

8. At the **FRONT** of the valve remove all parts connected to the spool (handle, linkage, etc.).

9. At the **FRONT** of the valve remove seal plate retainer, seal retainer, back-up washer and spool O-ring seal.

10. Thoroughly clean counterbore.

11. Lightly oil new O-ring seal. Slide O-ring seal over valve spool and insert in seal counterbore. Replace back-up washer, seal retainer, and seal plate retainer.

12. Reattach all parts connected to the spool (handle, linkage, etc.).

ASSEMBLY

Basic components for all models can be identified in Figure 9.

General:

The backhoe has been partially disassembled and strapped to a skid for shipping purposes. Initial installation on the tractor will require a hoist or other device capable of safely lifting the entire backhoe from the skid. After the initial installation is complete, the backhoe can serve as its own erecting hoist, by lowering stabilizers and bucket to the ground. Additional lifting devices will not be required for normal removal and reattaching.

Figure 9

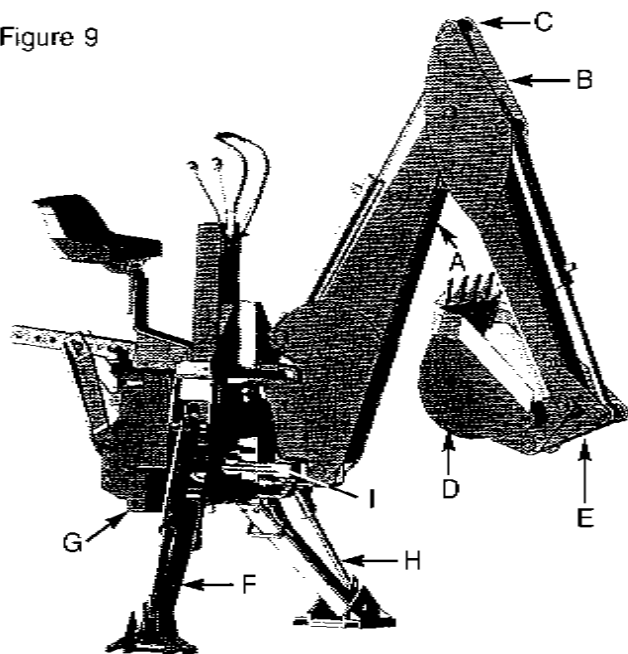

Assembly - Figure 9

IMPORTANT: Tighten all hardware to torque requirements specified in torque chart.

1. Remove the stabilizer assemblies and any miscellaneous items which have been fastened to the skid and arrange conveniently.

Reposition stabilizer cylinders from their shipping configuration (See Fig. 10), by assembling them into the Mainframe, using pins and hardware provided. Be sure cylinder ports are pointed upward and hoses are routed above the cylinder to mainframe pivot pin connection. See Fig. 11.

CAUTION

DO NOT cut any strapping that fastens the backhoe mainframe and swing frame to the skid base at this time.

2. Support boom (A) and dipperstick (B) with hoist and remove boom transport lock pin. Lower boom and manually extend dipperstick until it rests on ground. Move control handle to "BOOM DOWN" position as required to aid movement.

CAUTION

Be sure hoist being used is suitable, has sufficient capacity and is in the proper position. Do not allow anyone under a backhoe member supported by hoist.

3. Remove plastic bag containing bucket pins from backhoe. Attach Bucket (D) to Dipperstick using one pin, two bolts, locknuts, pin retainers, and washers as needed to take up gap under pin retainers.

4. Attach Bucket Link (E) to Bucket, using same hardware as listed for step #3.

5. Reposition hoist on backhoe to prevent tipping and raise Mainframe slightly. Remove all remaining strapping and skid. Using caution to prevent tipping, raise Mainframe (G) approximately 10" and block

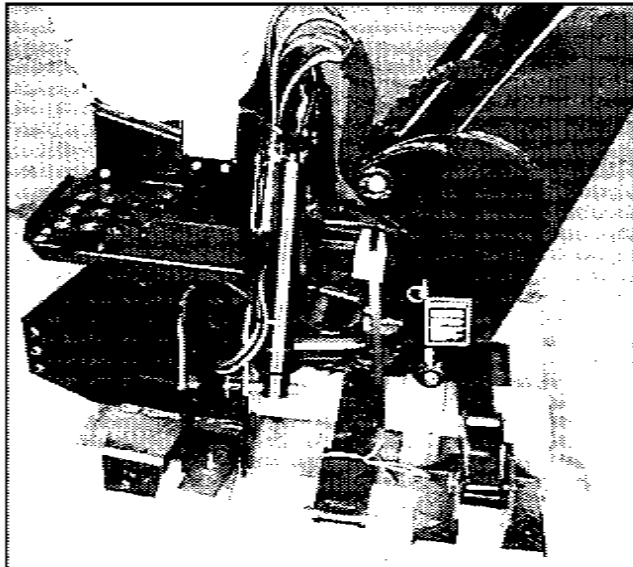

Figure 10

Mainframe and Swing Frame securely.

6. Attach Stabilizers (F) to Mainframe (G) using pins and hardware assembled to Stabilizers (F).

7. Attach Stabilizer Cylinders (H) to stabilizers (F) using pins and hardware assembled to Stabilizers (F).

8. Follow the Attaching Kit Assembly Instructions to mount the backhoe to the tractor. Check the installation carefully and make sure that all members are correctly installed and securely fastened.

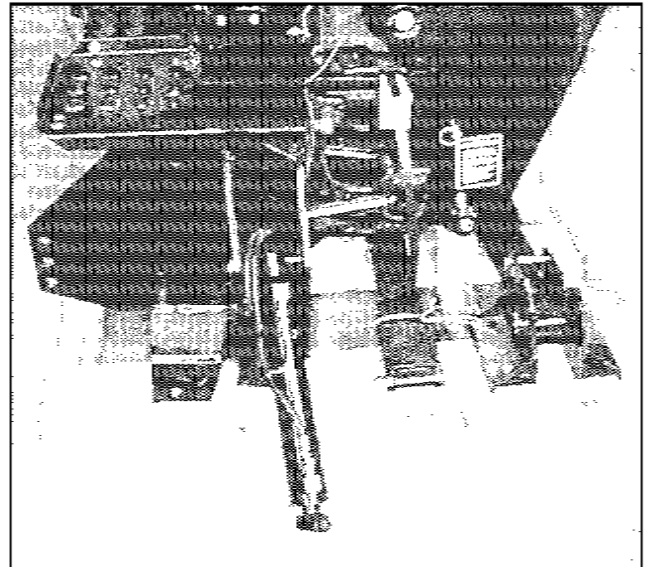

Figure 11

ATTACHING KIT INSTRUCTIONS

3-POINT HITCH LINKAGE & HYDRAULIC HOOK-UP TO TRACTOR HYDRAULIC SYSTEMS

General Description

Mounting and hydraulics kits may include two hoses which can be used to connect the backhoe control valve to the tractor hydraulic system. Additional hydraulic components or kits will be required to complete the hook-up to the tractor hydraulic system. Refer to the Hydraulic Hook-up section for further information. Pumps and reservoir kits are available as options.

The backhoe is mounted on the tractor lower link arms and an adjustable upper link is supplied to replace the tractor upper link. A set of stabilizer arms is included. They bolt from the adjustable upper link to the backhoe mainframe, locking the hoe rigidly in one position.

IMPORTANT: Tractor lower links must be kept free of lifting forces at all times after installation of the attaching kit, by keeping tractor quadrant lever in the lowered position.

IMPORTANT: If the 3-Point Kit is to be used with a PTO & Reservoir Kit, the Reservoir Tank and it's fittings should be installed before proceeding with the 3-Point installation.

ASSEMBLY (Refer to Figures 12 & 13)

IMPORTANT: Tighten all hardware to the torque requirements specified in the torque chart.

⚠ WARNING ⚠

To prevent bodily injury, do not operate backhoe unless Lower Link Weldments (1, 2) are properly installed and adjusted. Failure to do so may result in backhoe being thrust upward, crushing operator against cab or ROPS.

1. Use hoist to raise the backhoe mainframe so that the boom pivot pin is approximately 14" off the ground.

2. Back tractor close to the backhoe. Connect tractor lower link arms to lower link mounts at position "C", Figure 13, using two L-pins (3), two cotter pins (4), and two wire form cotter pins (5) as shown in Figure 13.

NOTE: If tractor has a Category II hitch, install two bushings (6) in lower link arms as shown in Figure 13.

3. Attach upper braces (7), Figure 14 to backhoe with 3/4 x 7-1/2" bolt (8), lockwasher (9), flat washers (10) and nut (11). Do not tighten hardware at this time.

4. Install bushing (12) or bushing (13) in the hole of the upper bar (14) that most closely matches the diameter of the tractor upper link pin, as shown in Figure 13. No bushing is necessary for Category II tractors.

5. Secure upper bar (14) between upper braces (7)

using 3/4 x 4-1/2" bolt (21), flat washers (10), lockwasher (9) and nut (11). Use hoist to raise or lower backhoe slightly until a hole in the upper bar aligns with a hole in the upper braces. See Figure 12.

6. Attach RH lower link weldment (1) and LH lower link weldment (2) to backhoe mainframe using 3/4 x 2-1/4" bolt (15), flat washer (10), lockwasher (9), and nut (11). See Figure 13.

7. Align RH and LH link weldment (1, 2) with a hole in the upper bar/brace assembly, as close to the tractor as possible. Use 3/4 x 6" bolt (16), flat washer (10), lockwasher (9), and nut (11). See Figure 13. You may need to return to Step 6 and readjust upward or downward the bolt connection.

8. Remove backhoe from the tractor.

9. Install connector plate (17) to RH and LH lower link weldments (1, 2) using 1/2 x 1-3/4" bolt (18), lockwasher (19), and nut (20). See Figure 13.

10. Tighten all hardware at this time. Check your installation very carefully to be sure all members are correctly installed and securely fastened.

10A. If using optional PTO Pump and Reservoir Kit proceed to that section prior to remounting the backhoe onto the tractor.

11. Connect hoses from the backhoe control valve to the tractor hydraulic system as described in "Hydraulic Hook-Up" section, prior to remounting the backhoe onto the tractor.

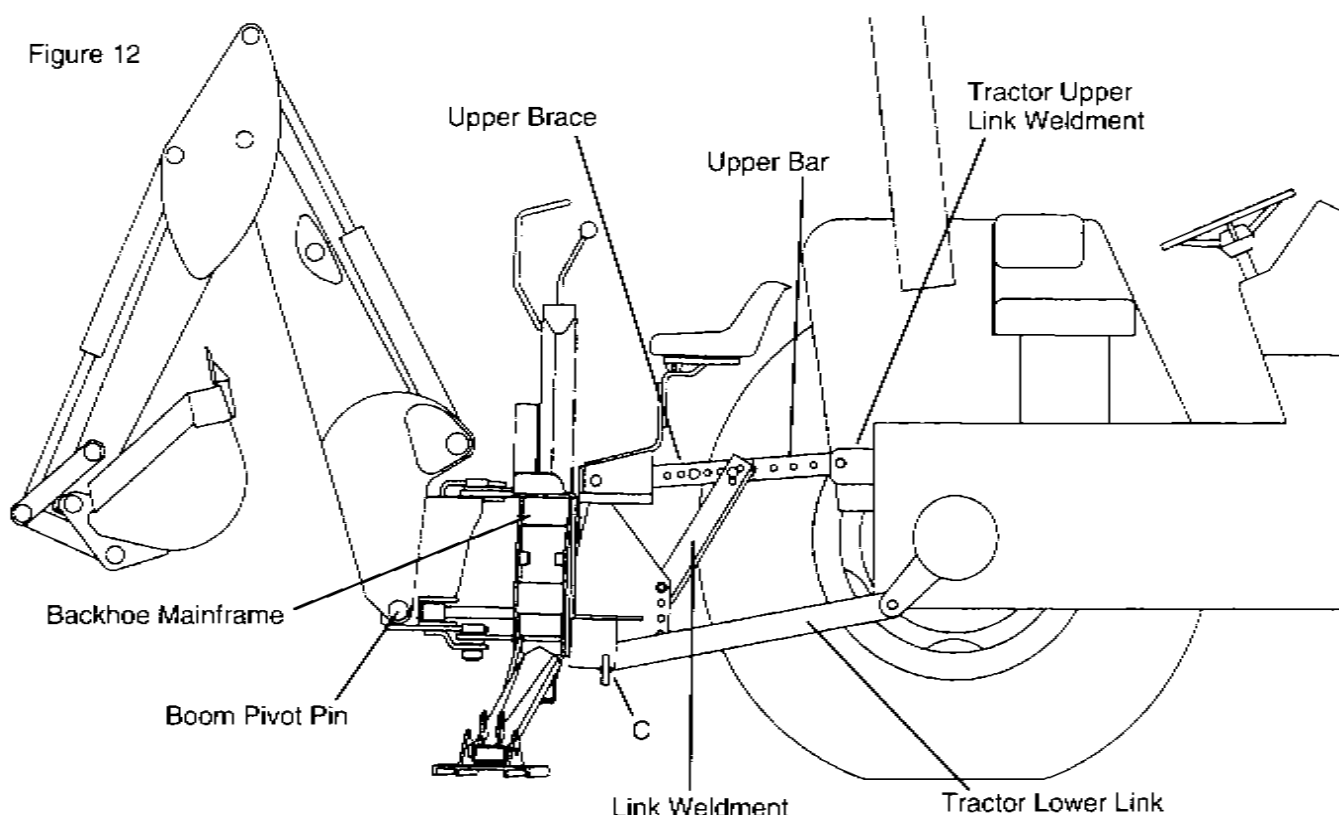
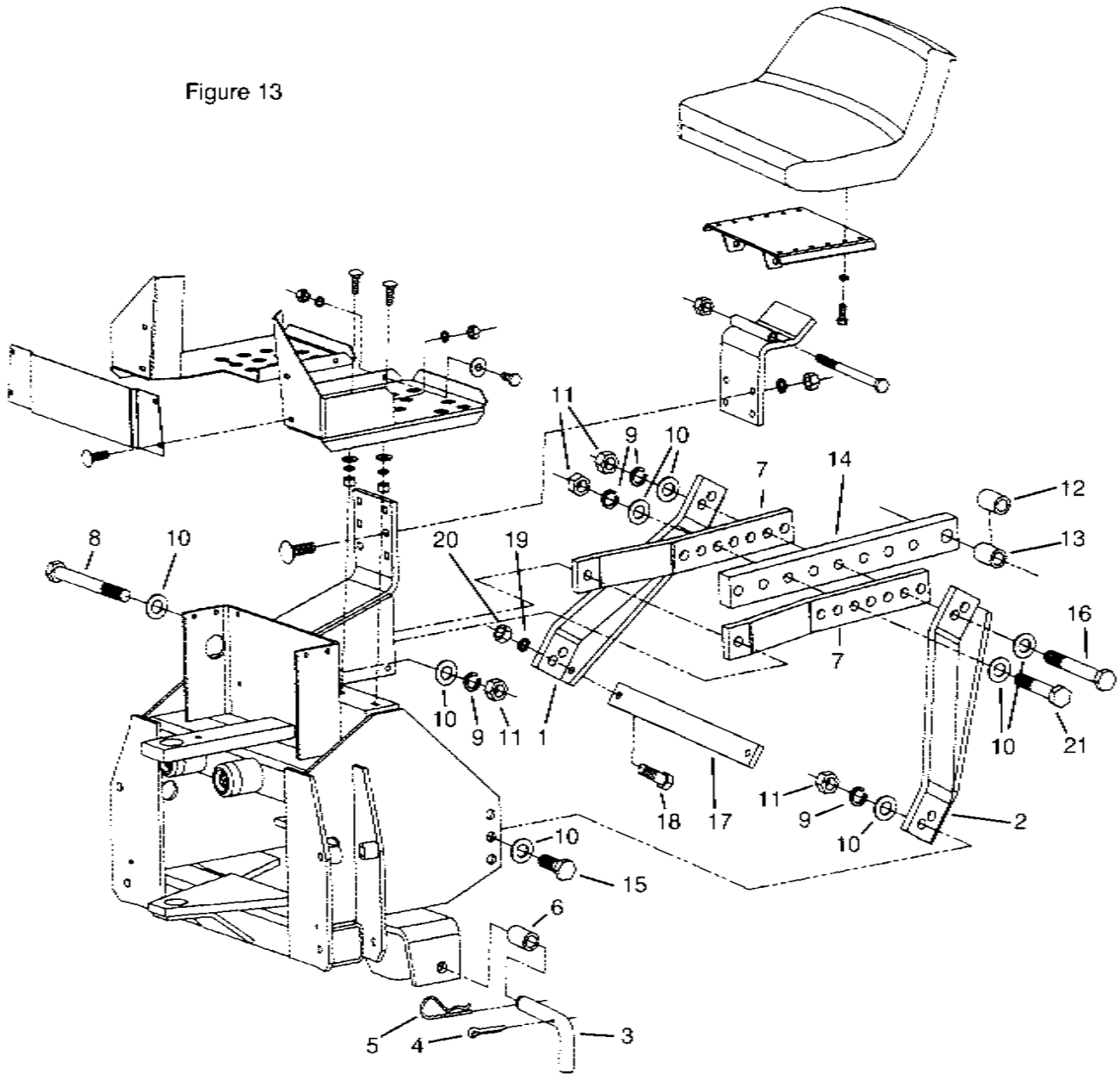

Figure 13



Hydraulic Hook-Up

If the optional Pump and Reservoir Kit is to be used, refer to the instructions for that kit for proper assembly.

There are four basic methods of hooking up the backhoe to the hydraulic system of a tractor. The correct method for the particular tractor will depend on the remote couplers available, whether a loader valve or other accessory valve is connected to the tractor system, and whether the tractor has an open-center system (constant pumping of oil to control valve and back to reservoir) or a closed-center system (no flow of oil until there is a demand at one hydraulic cylinder). The four hook up methods are described below.

IMPORTANT: Follow instructions carefully when connecting backhoe to tractor hydraulic system.

The decal shown below is located on the Left Hand toe shield.

IMPORTANT

IMPROPER HYDRAULIC HOOK-UP CAN CAUSE SERIOUS DAMAGE TO VALVE

- REFER TO ATTACHING KIT OR PTO PUMP KIT MANUAL FOR PROPER HYDRAULIC HOOK-UP.
- NEVER PRESSURIZE RETURN PORT OF VALVE OR RESTRICT RETURN HOSE.
- ALWAYS MOVE TRACTOR 3-POINT HITCH CONTROL TO FULLY LOWERED POSITION WHILE BACKHOE IS MOUNTED TO TRACTOR.

Note: Do not connect hoses from the backhoe control valve to the tractor hydraulic system until initial assembly of mounting kit is complete.

1. OPEN-CENTER SYSTEM WITH LOADER VALVE OR OTHER ACCESSORY VALVE CONNECTED TO THE TRACTOR HYDRAULIC SYSTEM:

When a loader valve or other accessory valve must be connected to the tractor hydraulic system in addition to the backhoe control valve, a **Power Beyond Kit** is required. This kit converts the backhoe valve so that pressurized hydraulic oil can be directed to another open-center valve for a loader or other accessory. This allows the backhoe valve and the other valve to be connected to the tractor hydraulic system simultaneously, without the inconvenience of using a flow diverting valve.

Since the Power Beyond Kit is used with open-center tractor hydraulic systems, oil constantly flows from the pump, through the backhoe valve and the loader valve or other accessory valve, and then to the reservoir. See further in this manual for instructions on proper assembly.

2. CLOSED CENTER SYSTEM:

Because a closed-center system requires no flow of oil through the backhoe control valve when the levers are in neutral position, the **backhoes must not be connected to a closed-center tractor hydraulic system**. A PTO pump kit is required if the tractor is to be mounted to a tractor with closed-center hydraulic system.

IMPORTANT: Do not connect a backhoe control valve to a closed-center tractor hydraulic system, or serious damage to backhoe valve or tractor hydraulic system may result.

3. OPEN-CENTER SYSTEM WITH RETURN OIL NOT REQUIRED FOR LUBRICATION - Figure 14

The pressure hose (A) on the backhoe control valve should be connected to the pressure port of the tractor's remote couplers or directly to the tractor valve. The return hose (B) on the backhoe control valve should be connected directly to a port on the reservoir, as shown in Figure 14.

IMPORTANT: Never connect the return hose to a tractor remote coupler which can be pressurized. Accidental pressurization can cause serious damage to backhoe valve.

4. OPEN-CENTER SYSTEM WITH RETURN OIL REQUIRED FOR LUBRICATION - Figure 15

On some tractors, the return oil cannot be routed directly to the reservoir because it is required for the lubrication of other functions. Check this characteristic with your dealer. The pressure hose (A) on the backhoe control valve must be connected to the pressure port of the tractor's remote couplers or directly to the tractor valve. The return hose (B) on the backhoe control valve must be connected to a surge relief valve as shown in Figure 15.

Note: The surge relief valve is not supplied with the backhoe or mounting kit and must be ordered separately to complete this type hydraulic hook-up.

Complete the hydraulic hook-up by connecting the surge relief valve to the return port of tractor remote couplers or directly to the tractor valve, and by connecting a hose from the TANK port of the surge relief valve to the tractor reservoir as shown in Figure 15. The surge relief valve is used to protect the backhoe valve from damage caused by accidental pressurization or high back pressure build-up. If this happens, oil will be vented from the TANK port of the surge relief valve to the tractor reservoir to prevent loss of vented oil.

Figure 14

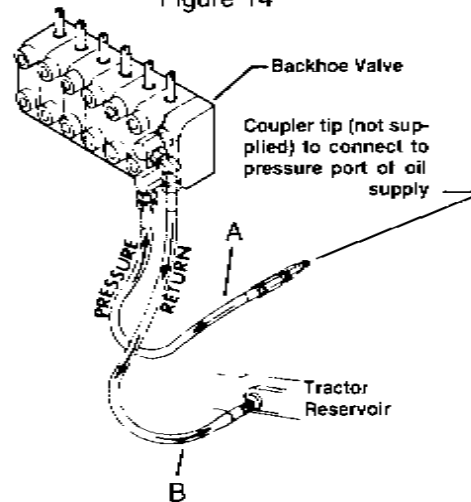
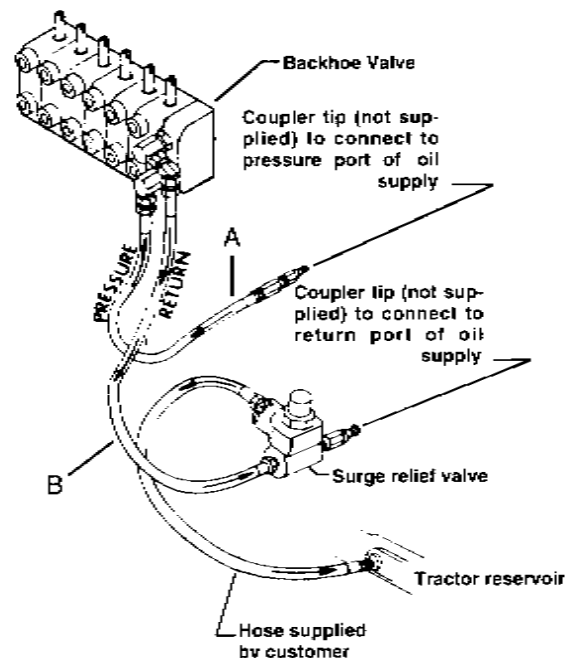

Figure 15



PTO PUMP AND RESERVOIR KIT (Optional)

General Description

The PTO Pump Kit consists of those parts required to power the backhoe from the tractor's PTO shaft. It includes the PTO pump and adapter, reservoir, filtration system, hydraulic hoses and fittings. In addition, it includes a pump torque arm which attaches to the tractor's lower link and keeps the pump from turning with the PTO shaft.

Note: The speed of the backhoe operation increases as PTO speed increases.

Assembly

Note: When installing hoses and fittings always use thread sealant in permanent connections. Do not use thread sealant in union ends of adapters. Do not overtighten fittings - they can split or expand, causing leakage

1. Assemble filler tube (1) and breather cap with dipstick (2) to reservoir (3) as shown in Figure 16.

2. Assemble reservoir (3) to backhoe: Use 5/16 x 7/8" bolt (35), flat washer (36), and lock-nut (38) as shown in Figure 16.

3. Assemble suction hose (4) to reservoir (3) using street elbow (5), hose nipple (6), and hose clamp (7) as shown in Figure 16.

4. Preassembly of filter base and element (8): Assemble pipe bushing (9), and 15" hose (10) to Inlet port on filter base (8) as shown in Figure 16. Assemble pipe bushing (9) and adapter union (11) to Outlet port on filter base (8) as shown in Figure 16.

5. Assemble filter base and element (8) to Left Hand Foot Pad on backhoe using 1/4 x 3/4" bolt (13), lock-washer (14), and flat washer (15) as shown in Figure 16.

NOTE - Change filter element (16) every time oil is changed.

6. Connect return line hose (10) to "OUT" port on backhoe control valve.

7. Complete connection between filter base (8) Outlet port and reservoir (3) using 29" hose (17), pipe bushing (9), and street elbow (5) as shown in Figure 16.

8. Assemble torque arm (18) to pump (19), using hardware provided (20, 21, 22), as shown in Figure 16. Pump plate may have to be readjusted later.

9. Slide PTO adapter (23) onto pump shaft allowing 1/8" between adapter and pump face and secure with two setscrews (24), as shown in Figure 16. Lock with

two nuts (25).

10. **W602** - Assemble suction hose (4) to pump (19), using pipe adapter (26), street elbow (5), hose nipple (6), and hose clamp (7) as shown in Figure 16.

W702 - Assemble suction hose (4) to pump (19), using pipe adapters (26, 27), street elbow (5), hose nipple (6), and hose clamp (7) as shown in Figure 16.

11. **NOTE:** Pressure line is routed under the reservoir tank for W702 kit and over for W602 kit. To ease installation of pressure line, tank should be loosened and 90 degree hydraulic fitting in control valve "IN" port removed. Attach 90 degree fitting to hose, reinstall fitting and proceed as noted below.

W602 - Connect pressure line between valve "IN" port fitting and pump, using adapter union (28) and hose (12) as shown in Figure 16.

W702 - Connect pressure line between valve "IN" port fitting and pump, using adapter unions (28, 29) and hose (12) as shown in Figure 16.

IMPORTANT - If hoses are hooked up incorrectly, serious damage to the backhoe valve will result.

12. **NOTE:** Initial fill up of the Reservoir Tank will require 4fi gallons of fluid. Fill reservoir with recommended fluid to correct level, referring to Service Section in the Backhoe Manual.

13. Mount the backhoe to the tractor at this time following the procedure in the Attaching Kit Manual.

14. Slide complete pump assembly onto the PTO shaft and secure with lock pin on PTO adapter. Be sure kinks do not develop in any of the lines. Suction hose can be shortened to prevent this problem.



DO NOT REMOVE THE TRACTOR PTO GUARD

15. Attach torque arm (18) to tractor's lower link using hook-up chain (30), 3/8 x 2" bolt (31), washer (32), lockwasher (21), and nut (22), as shown in Figure 16. Torque arm (18) may be adjusted on pump (19) for proper fit-up to lower link if necessary.

IMPORTANT - When mounting backhoe on the adapter, do not let the swing cylinders interfere with the backhoe pump, or the hydraulic lines become tangled in any part of the adapter during installation. Make sure both pressure and suction lines are free from kinks or twists to reduce back pressure and excessive heat build-up.

PTO PUMP AND RESERVOIR KIT PARTS BREAKDOWN W602 7-1/2' BACKHOE

Figure 16

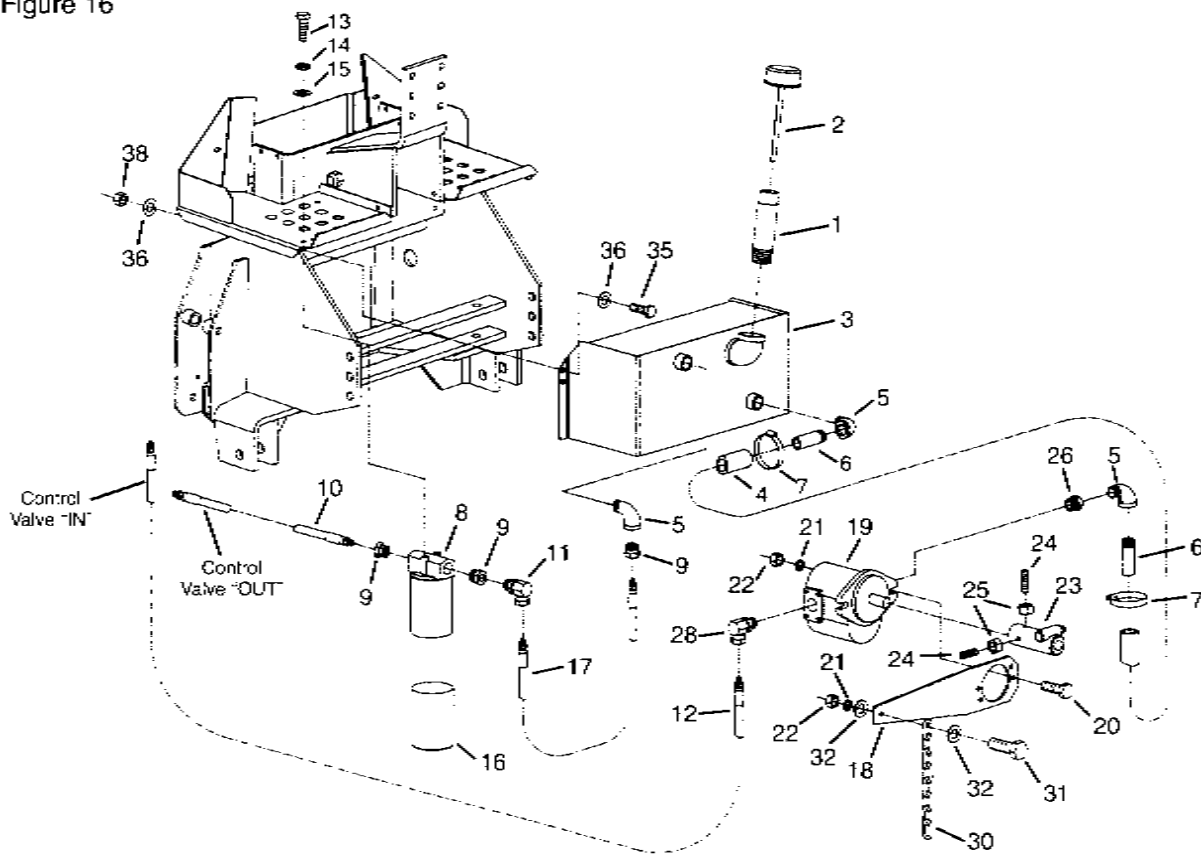

Index Number	Part Number	Description	Index Number	Part Number	Description
1	860296	Filler Tube	17	17519	Hydraulic Hose, 1/2" NPTM x 1/2" NPTM x 29" long
2	23067	Breather Cap with Dipstick	18	850695	Torque Arm
3	15526	Reservoir Tank	19	10173	Hydraulic Pump
4	11026	Suction Hose	20	6857	Bolt, 3/8" NF x 1-1/4"
5	7975	Street Elbow, 3/4" NPTM x 3/4" NPTF x 90°	21	8079	Lockwasher, 3/8"
6	780833	Hose Nipple	22	7451	Nut, 3/8" NC
7	14150	Hose Clamp - 1-1/16" to 2"	23	15046	PTO Adapter
8	10375	Filter Base and Element	24	8327	Setscrew, 5/16" NC x 3/4" Cup Point
9	7987	Reducer - 3/4" NPTM x 1/2" NPTF	25	7431	Nut, 5/16" NC
10	17507	Hydraulic Hose, 1/2" NPTM x 1/2" NPTM x 15" long	26	11237	Reducer, 1-3/16-12 SAE Str. Thrd. x 3/4" NPTF
11	11129	Adapter Union, 1/2" NPTM x 1/2" NPTF x 90°	28	11142	Adapter Union, 7/8-14 SAE x 1/2" NPTF x 90°
12	17538	Hydraulic Hose, 1/2" NPTM x 1/2" NPTM x 38" long	30	851834	Hook-up Chain
13	6740	Bolt, 1/4" NC x 3/4"	31	6872	Bolt, 3/8" NC x 2"
14	8061	Lockwasher, 1/4"	32	8156	Flat Washer, 3/8"
15	8146	Flat Washer, 1/4"	35	6790	Bolt, 5/16" NF x 7/8" Grade 5
16	10376	Element Only (Service Only)	36	8152	Flat Washer, 5/16" SAE
			38	7437	Locknut, 5/16" NF

PTO PUMP AND RESERVOIR KIT PARTS BREAKDOWN W702 7-1/2' BACKHOE

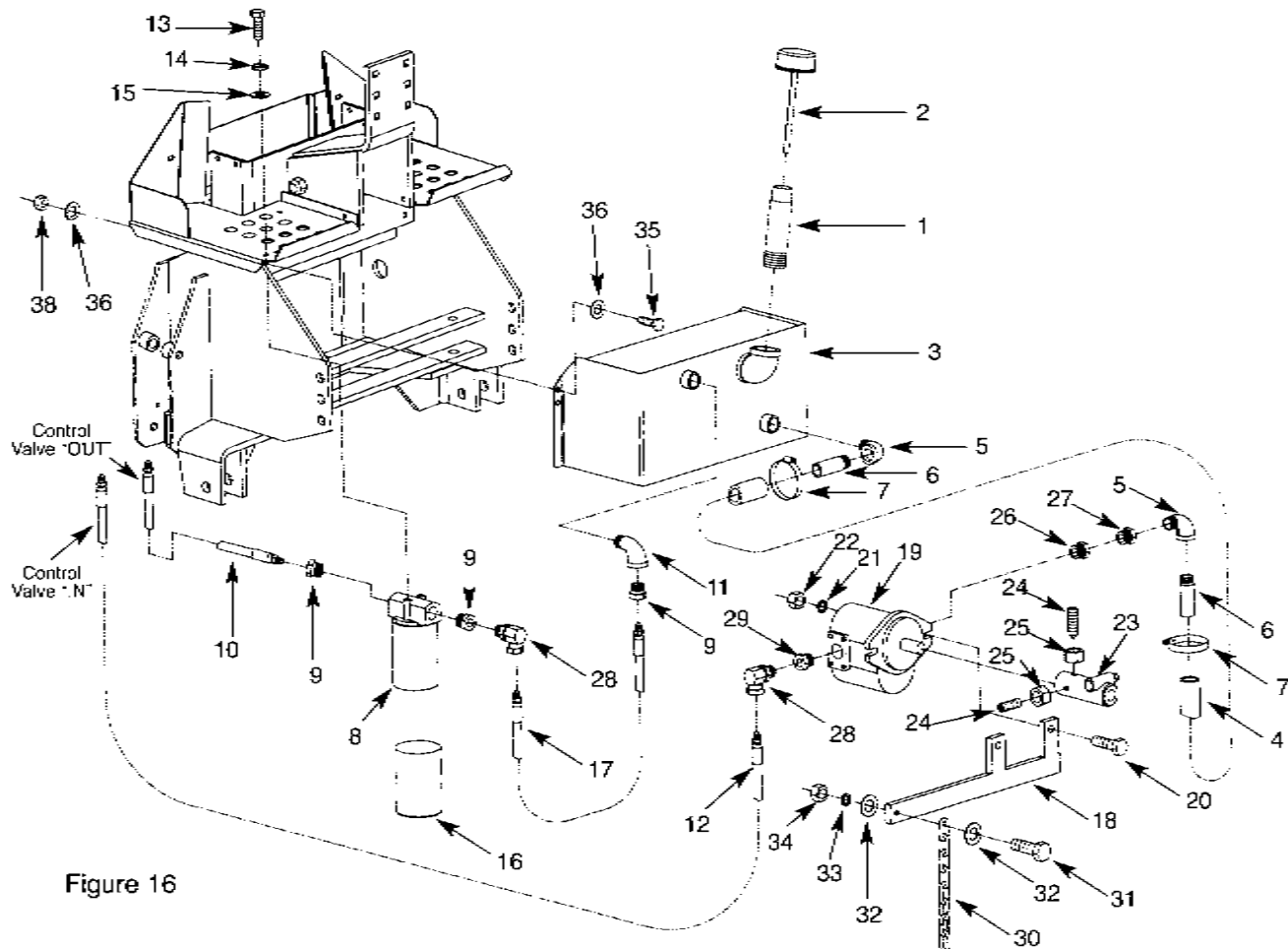
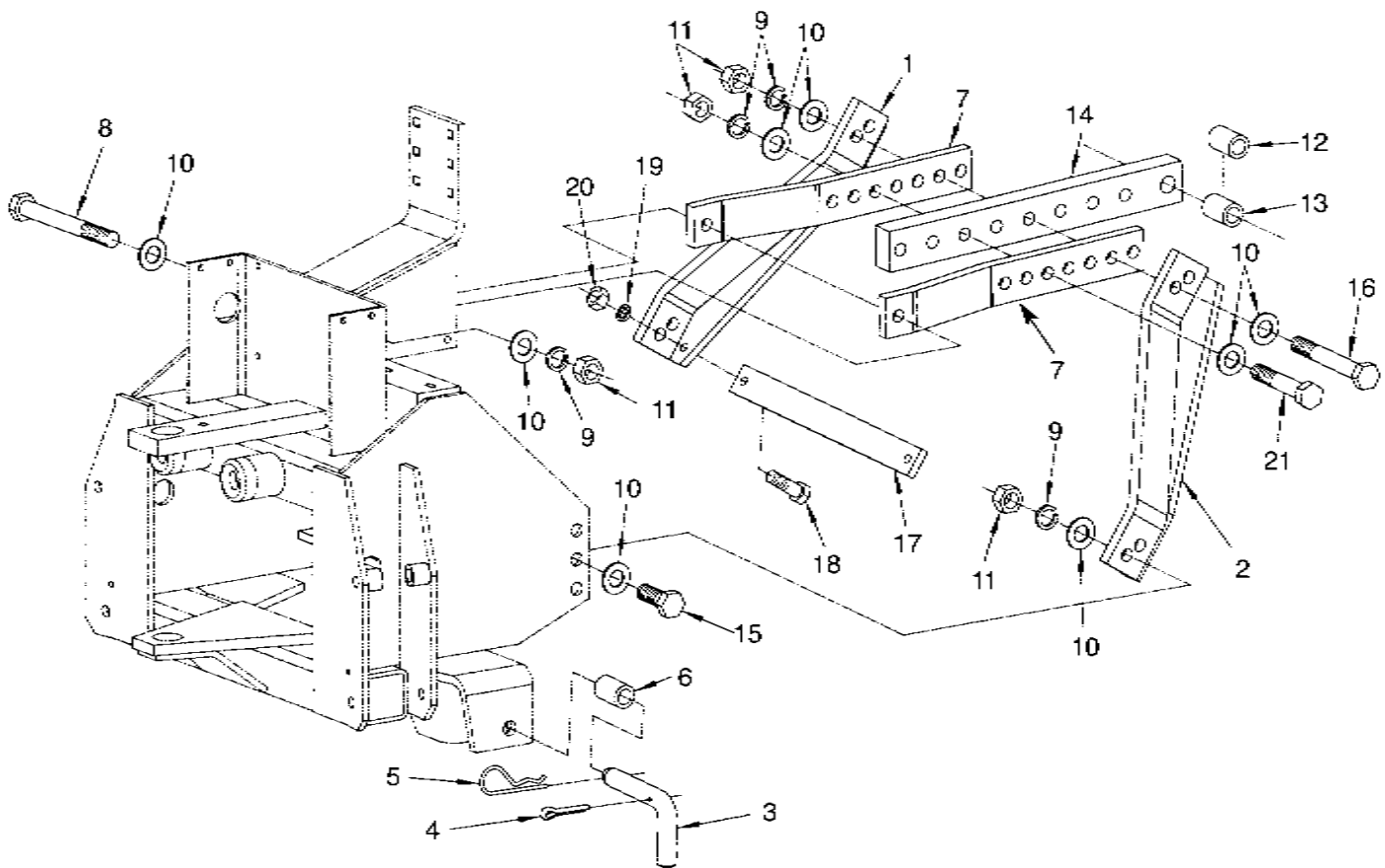

Figure 16

Index Number	Part Number	Description	Index Number	Part Number	Description
1	860296	Filler Tube	19	23072	Hydraulic Pump
2	23067	Breather Cap with Dipstick	20	7034	Bolt, 1/2" NF x 1-3/4" Gr. 5
3	15526	Reservoir Tank	21	8101	Lockwasher, 1/2"
4	11026	Suction Hose	22	7511	Nut, 1/2" NF
5	7975	Street Elbow, 3/4" NPTM x 3/4" NPTF x 90°	23	15093	PTO Adapter
6	780833	Hose Nipple	24	8327	Setscrew, 5/16" NC x 3/4" Cup Point
7	14150	Hose Clamp - 1-1/16" to 2"	25	7431	Nut, 5/16" NC
8	10375	Filter Base and Element	26	11216	Reducer, 1-5/8-12 SAE Str. Thrd. x 1" NPTF
9	7987	Reducer - 3/4" NPTM x 1/2" NPTF	27	8015	Reducer - 1" NPTM x 3/4" NPTF
10	17507	Hydraulic Hose, 1/2" NPTM x 1/2" NPTM x 15" long	28	11129	Adapter Union, 1/2" NPTM x 1/2" NPTF x 90°
11	7974	Street Elbow, 3/4" NPTM x 3/4" NPTF x 45°	29	11227	Reducer, 1-1/16-12 SAE Str. Thrd. x 1" NPTF
12	17538	Hydraulic Hose, 1/2" NPTM x 1/2" NPTM x 38" long	30	851834	Hook-up Chain
13	6740	Bolt, 1/4" NC x 3/4"	31	6882	Bolt, 3/8 NC x 2-1/2"
14	8061	Lockwasher, 1/4"	32	8156	Flat Washer, 3/8"
15	8146	Flat Washer, 1/4"	33	8079	Lockwasher, 3/8"
16	10376	Element Only (Service Only)	34	7451	Nut, 3/8" NC
17	17519	Hydraulic Hose, 1/2" NPTM x 1/2" NPTM x 29" long	35	6789	Bolt, 5/16" NF x 3/4"
18	858135	Torque Arm	36	8152	Flat Washer, 5/16" SAE
			38	7437	Locknut, 5/16" NF

3-POINT MOUNT KIT PARTS BREAKDOWN W601 7-1/2' BACKHOE



Index Number	Part Number	Description	Index Number	Part Number	Description
1	860280	RH Lower Link Weldment	13	854528	Bushing, (optional) 1" O.D. x 13/16" I.D. x 1-5/8" long
2	860285	LH Lower Link Weldment	14	860291	Upper Bar
3	775003	L-Pin	15	7250	Bolt, 3/4" NF x 2-1/4" Gr. 5
4	8582	Cotter Pin, 3/16" x 1-1/4"	16	7270	Bolt, 3/4" NF x 6" Gr. 5
5	8624	Wire Form Cotter #10	17	860288	Connector Plate
6	852198	Lower Link Cat. II Bushing (optional)	18	7034	Bolt, 1/2" NF x 1-3/4" Gr. 5
7	860292	Upper Brace	19	8101	Lockwasher, 1/2"
8	7273	Bolt, 3/4" NF x 7-1/2" Gr. 8	20	7511	Nut, 1/2" NF
9	8121	Lockwasher, 3/4"	21	7260	Bolt, 3/4" NF x 4-1/2" Gr. 8
10	8192	Flat Washer, 3/4"			
11	7569	Nut, 3/4" NF			
12	750253	Bushing, (optional) 1" O.D. x 3/4" I.D. x 1-5/8" long			

W604 STREET PAD KIT

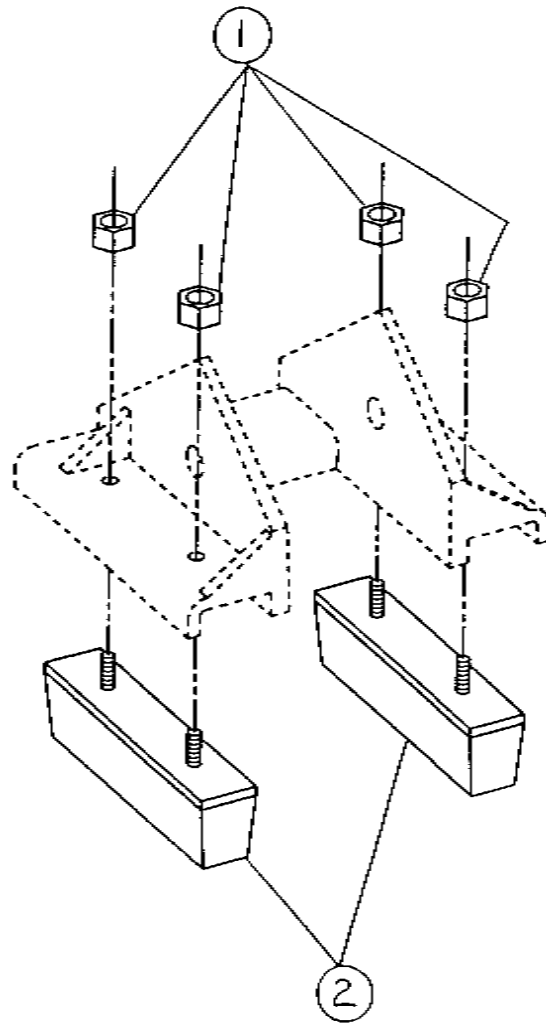

Index No.	Part Number	Description
1	7458	Locknut, 3/8 NC
2	12899	Street Pad - Rubber

REGULAR DUTY DEEP PROFILE BUCKET PARTS BREAKDOWN FOR 7-1/2' BACKHOES

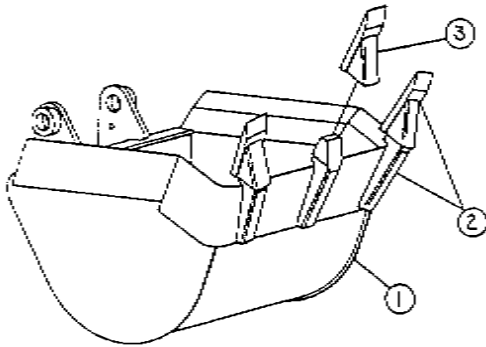

Index Number	Part Number	Description
1	W610	Regular Duty Deep Profile Bucket - 9"
2	13613	Tooth and Shank Assemblies for 9" Bucket
3	13617	Tooth Point Only for 9" Bucket
1	W611	Regular Duty Deep Profile Bucket - 13"
2	13613	Tooth and Shank Assemblies for 13" Bucket
3	13617	Tooth Point Only for 13" Bucket
1	W612	Regular Duty Deep Profile Bucket - 16"
2	13613	Tooth and Shank Assemblies for 16" Bucket
3	13617	Tooth Point Only for 16" Bucket
1	W613	Regular Duty Deep Profile Bucket - 20"
2	13613	Tooth and Shank Assemblies for 20" Bucket
3	13617	Tooth Point Only for 20" Bucket
1	W614	Regular Duty Deep Profile Bucket - 24"
2	13613	Tooth and Shank Assemblies for 24" Bucket
3	13617	Tooth Point Only for 24" Bucket
1	W615	Regular Duty Deep Profile Bucket - 36"
2	13613	Tooth and Shank Assemblies for 36" Bucket
3	13617	Tooth Point Only for 36" Bucket

HEAVY DUTY DEEP PROFILE BUCKET PARTS BREAKDOWN FOR 7-1/2' BACKHOES

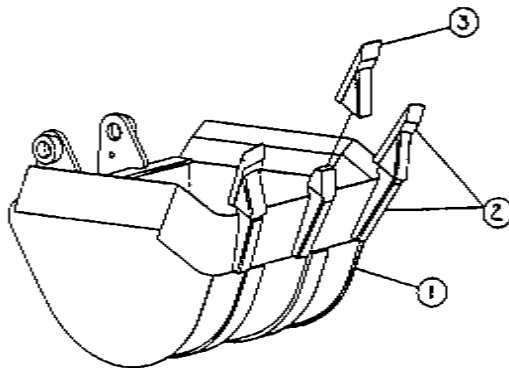

Index Number	Part Number	Description
1	W620	Heavy Duty Deep Profile Bucket - 9"
2	13626	Tooth and Shank Assemblies for 9" Bucket
3	13627	Tooth Point Only for 9" Bucket
1	W621	Heavy Duty Deep Profile Bucket - 13"
2	13626	Tooth and Shank Assemblies for 13" Bucket
3	13627	Tooth Point Only for 13" Bucket
1	W622	Heavy Duty Deep Profile Bucket - 16"
2	13626	Tooth and Shank Assemblies for 16" Bucket
3	13627	Tooth Point Only for 16" Bucket
1	W623	Heavy Duty Deep Profile Bucket - 20"
2	13626	Tooth and Shank Assemblies for 20" Bucket
3	13627	Tooth Point Only for 20" Bucket
1	W624	Heavy Duty Deep Profile Bucket - 24"
2	13626	Tooth and Shank Assemblies for 24" Bucket
3	13627	Tooth Point Only for 24" Bucket
1	W625	Heavy Duty Deep Profile Bucket - 36"
2	13626	Tooth and Shank Assemblies for 36" Bucket
3	13627	Tooth Point Only for 36" Bucket

Bucket Data:

BUCKET	WIDTH	SAE STRUCK CAPACITY	HEAPED CAPACITY	SHIPPING WEIGHT
W610	9"	.50 cu. ft.	.64 cu. ft.	46 lbs.
W611	13"	.78 cu. ft.	1.04 cu. ft.	52 lbs.
W612	16"	.98 cu. ft.	1.33 cu. ft.	57 lbs.
W613	20"	1.26 cu. ft.	1.74 cu. ft.	65 lbs.
W614	24"	1.54 cu. ft.	2.14 cu. ft.	78 lbs.
W615	36"	2.38 cu. ft.	3.34 cu. ft.	102 lbs.
W620	9"	.50 cu. ft.	.64 cu. ft.	53 lbs.
W621	13"	.78 cu. ft.	1.04 cu. ft.	61 lbs.
W622	16"	.98 cu. ft.	1.33 cu. ft.	66 lbs.
W623	20"	1.26 cu. ft.	1.74 cu. ft.	78 lbs.
W624	24"	1.54 cu. ft.	2.14 cu. ft.	89 lbs.
W625	36"	2.38 cu. ft.	3.34 cu. ft.	118 lbs.

PARTS BREAKDOWN 7-1/2' BACKHOE

Index No.	Part Number	Description
1	187	Hydraulic Cylinder Assembly
2	188	Hydraulic Cylinder
3	189	Hydraulic Cylinder
4	192	Hydraulic Cylinder
5	6574	Bolt, Carriage 5/16NC x 3/4
6	6577	Bolt, Carriage 5/16 NC x 1"
7	6669	Bolt, Carriage 1/2 NC x 1-3/4"
8	6740	Bolt, 1/4 NC x 3/4"
9	6787	Bolt, 5/16 NC x 3/4"
10	6788	Bolt, 5/16 NC x 3/4 Thread Forming
11	6789	Bolt, 5/16 NF x 3/4" Gr. 5
12	6790	Bolt, 5/16 NF x 7/8"
13	6795	Bolt, 5/16 NF x 1" Gr. 5
14	6798	Bolt, 5/16 NC x 1-1/4" Gr. 5
16	6801	Bolt, 5/16 NF x 1-1/8" Gr. 5
17	6808	Bolt, 5/16 NF x 2-1/4" Gr. 8
18	6806	Bolt, 5/16 NC x 3-1/4"
19	6819	Bolt, 5/16 NC x 2- 3/4"
20	6821	Bolt, 5/16 NF x 5" Gr. 5
21	6851	Bolt, 3/8 NF x 1"
22	6870	Bolt, 3/8 NF x 1-3/4"
23	6878	Bolt, 3/8 NF x 2-1/4" Gr.5
24	7088	Bolt, 1/2 NF x 6-1/2"
25	7403	Locknut, 1/4 NC
26	7431	Nut, 5/16 NC
27	7433	Locknut, 5/16 NC
28	7436	Nut, 5/16 NF
29	7437	Locknut, 5/16 NF
30	7466	Locknut, 3/8 NF
31	7501	Nut, 1/2 NC
32	7515	Locknut, 1/2 NF
33	7897	Pipe Plug
34	8071	Lockwasher, 5/16
35	8101	Lockwasher, 1/2
36	8151	Washer, 5/16 STD
37	8152	Flat Washer, 5/16 SAE
38	8158	Flat Washer, 3/8 SAE
39	8272	Machine Bushing, 1-1/4 OD x 3/4 ID x 14Ga.
40	8283	Machine Bushing 1-1/2" OD x 1" ID x 18Ga.
41	8290	Machine Bushing 1-7/8" OD x 1-1/4" ID x 18Ga.
42	8304	Machine Bushing, 2-1/2OD x 1-3/4 ID x 18Ga.
43	8582	Cotter Pin, 3/16 x 1-1/4"
44	8602	Cotter Pin, 1/4 x 2"
45	10166	Check Valve
46	11091	Adapter Union, 9/16-18M x 3/8NPTF
47	11095	Hydraulic Tee - Parker #012-6-6
48	11129	Adapter Union, 1/2NPTM x 1/2 NPTF x 90 degree
49	11131	Adapter Union, 1/2NPTM x 1/2 NPTF x 45 degree

PARTS BREAKDOWN CONTINUED

Index No.	Part Number	Description
50	11142	Adapter Union, 7/8-14M x 1/2 NPTF x 90 degree
51	11143	Adapter Union, 3/4-16M x 3/8NPTF x 90 degree
52	11978	Garlock Bearing, 028DXR016
53	12491	Stabilizer Pad Weldment
54	12907	Step Pad Surfacing 3" x 3"
55	13473	Pin Retainer
56	13495	Boom Lock Pin
57	13496	Swing Lock Pin
58	13679	Bumper
59	13683	SMV Socket
60	13919	Seat
61	14027	Ball Joint
62	14058	Control Knob
63	14085	Rubber Grommet
64	14132	Plastic Tie
65	14133	Plastic Tie
66	14137	Hose Sleeve
67	14140	Clamp
68	14162	Hose Sleeve
69	14505	Grease Fitting
70	14521	Grease Fitting x 45 degree
71	17017	Hydraulic Hose, 3/8NPTM x 3/8NPTM x 23" long
72	17047	Hydraulic Hose, 3/8NPTM x 3/8NPTM x 30" long
73	17048	Hydraulic Hose, 3/8NPTM x 3/8NPTM x 34" long
74	17110	Hydraulic Hose, 3/8NPTM x 3/8NPTM x 70" long
75	17135	Hydraulic Hose, 3/8NPTM x 3/8NPTM x 80" long
76	17200	Hydraulic Hose, 3/8NPTM x 3/8NPTM x 100" long
77	17220	Hydraulic Hose, 3/8NPTM x 3/8NPTM x 118" long
79	23062	Gresen V20 Control Valve
80	50817	Control Rod
81	50818	Stabilizer Lever Control Rods
82	50819	Stabilizer Control Lever
83	50831	Rear Shroud
84	851136	Thrust Washer
85	855151	Pivot Pin, Guide Link 1"Dia. x 7-3/8" Long
86	857124	Hose Strap
87	857921	SMV Socket Mount
88	858301	Pin Retainer
89	860240	Mainframe Weldment
90	860350	Swing Frame Weldment
91	860365	Dipperstick Weldment
92	860385	Boom Weldment
93	860399	Hose Clamp
94	860450	Lower Pivot Pin Weldment
95	860456	Pivot Pin, 3/4 Dia. x 4-1/16"
96	860457	Pivot Pin, Boom 1-1/4"Dia. x 8-5/8" Long
97	860458	Pivot Pin, Dipperstick 1-1/4"Dia. x 7-15/16" Long
98	860459	Pivot Pin, Stabilizer Leg 3/4"Dia. x 5-5/8" Long
99	860460	Pivot Pin Weldment

PARTS BREAKDOWN CONTINUED

Index No.	Part Number	Description
100	860466	Pivot Pin, Stabilizer Leg 3/4"Dia. x 4-15/16" Long
101	860467	Pivot Pin, Stabilizer Cyl. Rod 3/4"Dia. x 3-3/4" Long
102	860468	Pivot Pin, Boom Cyl. Rod 1-1/4"Dia. x 5-9/16" Long
103	860469	Pivot Pin, Dipper Cyl. Base 1-1/4"Dia. x 7-7/16" Long
104	860471	Pivot Pin, Dipper Cyl. Rod 1-1/4"Dia. x 6-5/16" Long
105	860472	Pivot Pin, Bucket Cyl. Base 1"Dia. x 5-7/8" Long
106	860474	Pivot Pin, Boom Cyl. Base 1-1/4"Dia. x 7-1/4" Long
108	860480	Stabilizer Leg Weldment
109	860485	Guide Link Weldment
110	860490	Bucket Link Weldment
111	860496	Valve Cover Plate
112	860500	RH Floor Plate Weldment
113	860505	LH Floor Plate Weldment
114	860260	Front Shroud Weldment with Decals
115	860515	Grab Bar Weldment
116	861675	Upper Pivot Pin Weldment
117	861700	Seat Plate Weldment
120	861708	Lever Bracket
122	863165	Right Hand Joystick Weldment
123	863170	Left Hand Joystick Weldment
124	861720	Seat Bracket Weldment
125	8554	Cotter Pin, 3/32 x 3/4
126	13436	Clevis Pin, 1/4 Dia x 7/8
127	6887	Bolt, 3/8 NF x 2-3/4"
129	6580	Bolt, Carriage 5/16 NC x 1-1/4" Gr. 5
130	860279	Spacer
131	14500	Grease Fitting
132	6779	Bolt, 5/16 NF x 5/8" gr. 5
133	11973	Bronze Bearing
134	863175	Right Hand Pivot Weldment
135	863180	Left Hand Pivot Weldment
136	863184	Bushing
137	14024	Ball Joint - Shouldered

CONTROL TOWER AREA

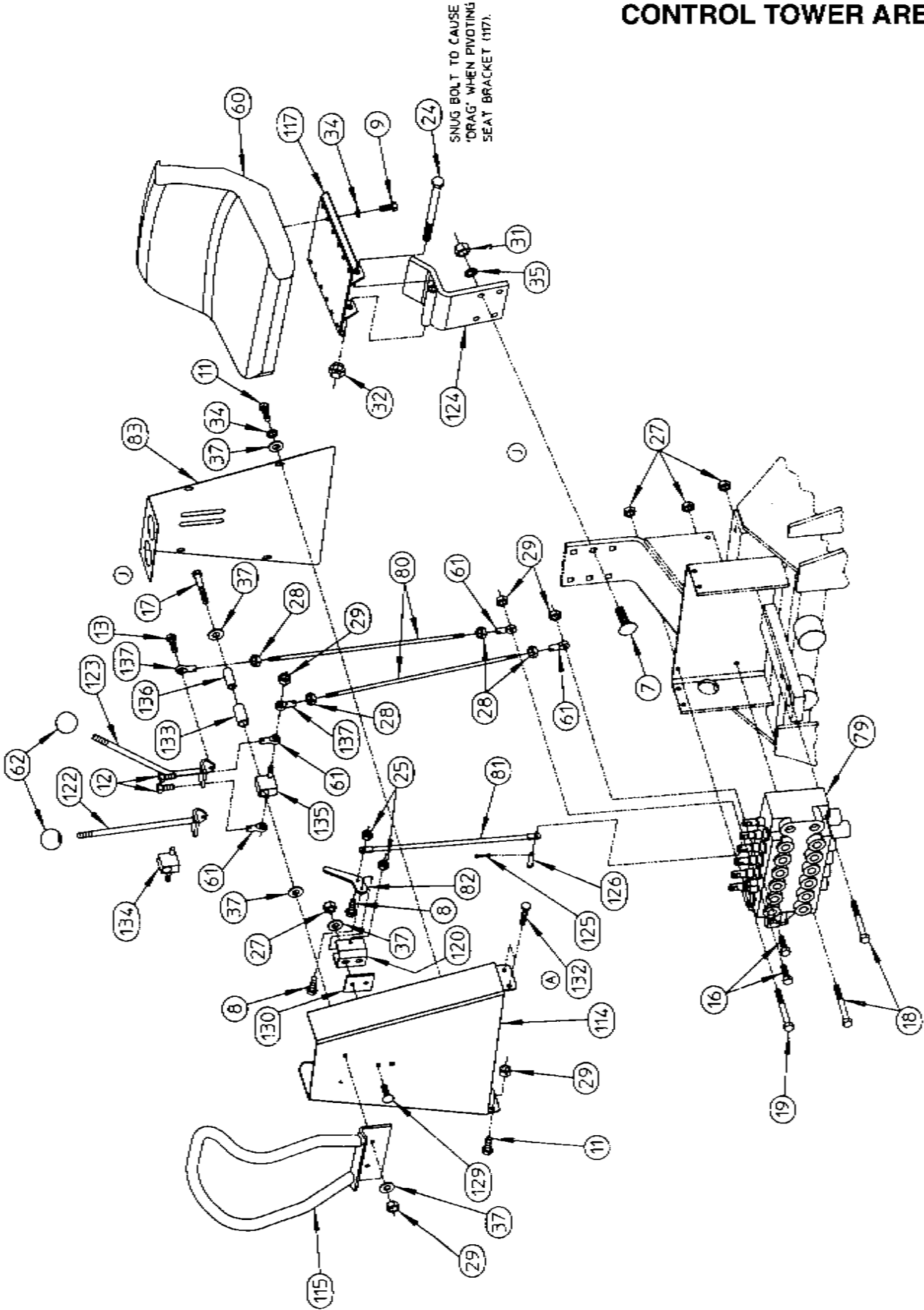

STABILIZER LEG AREA

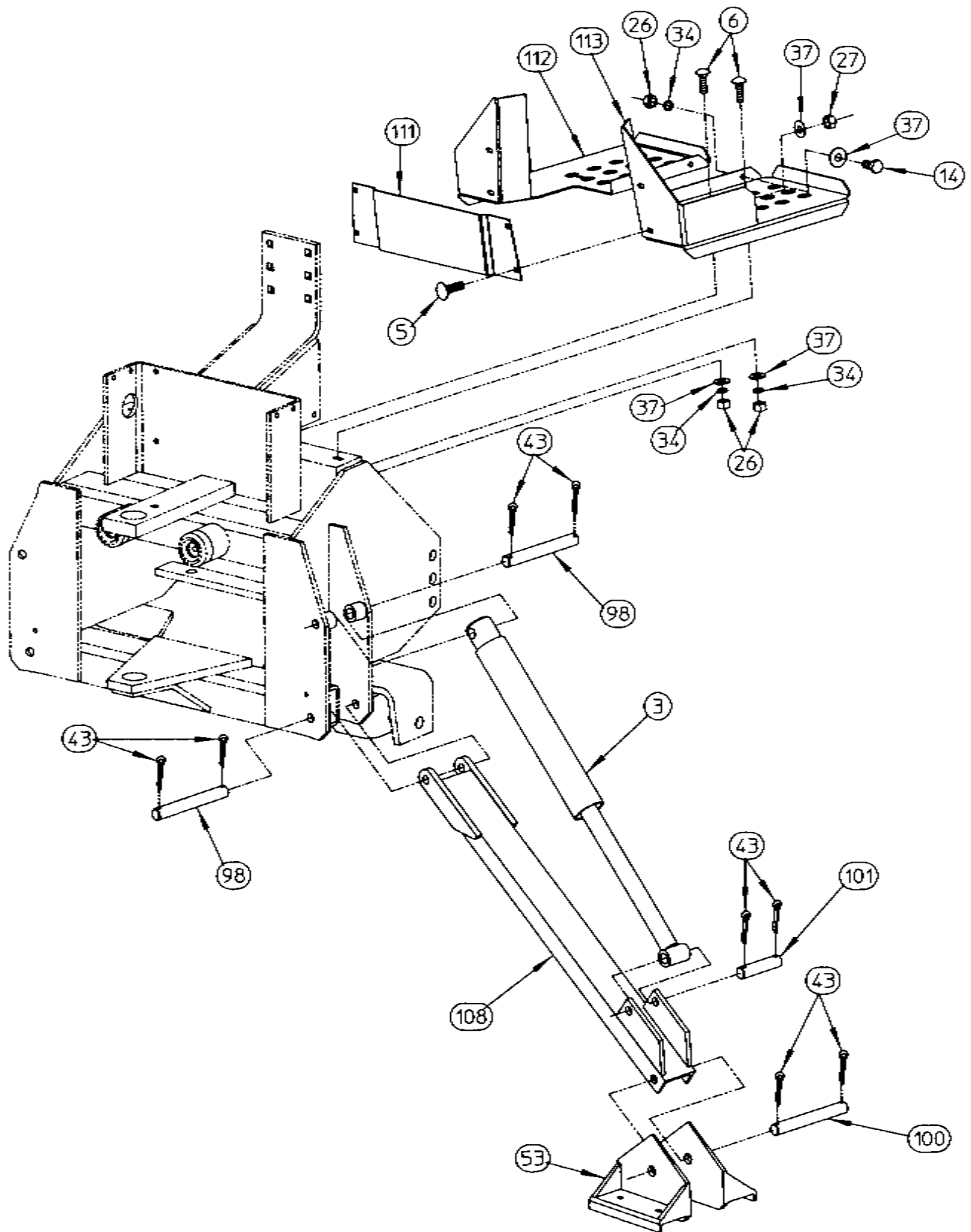

SWING SYSTEM AREA

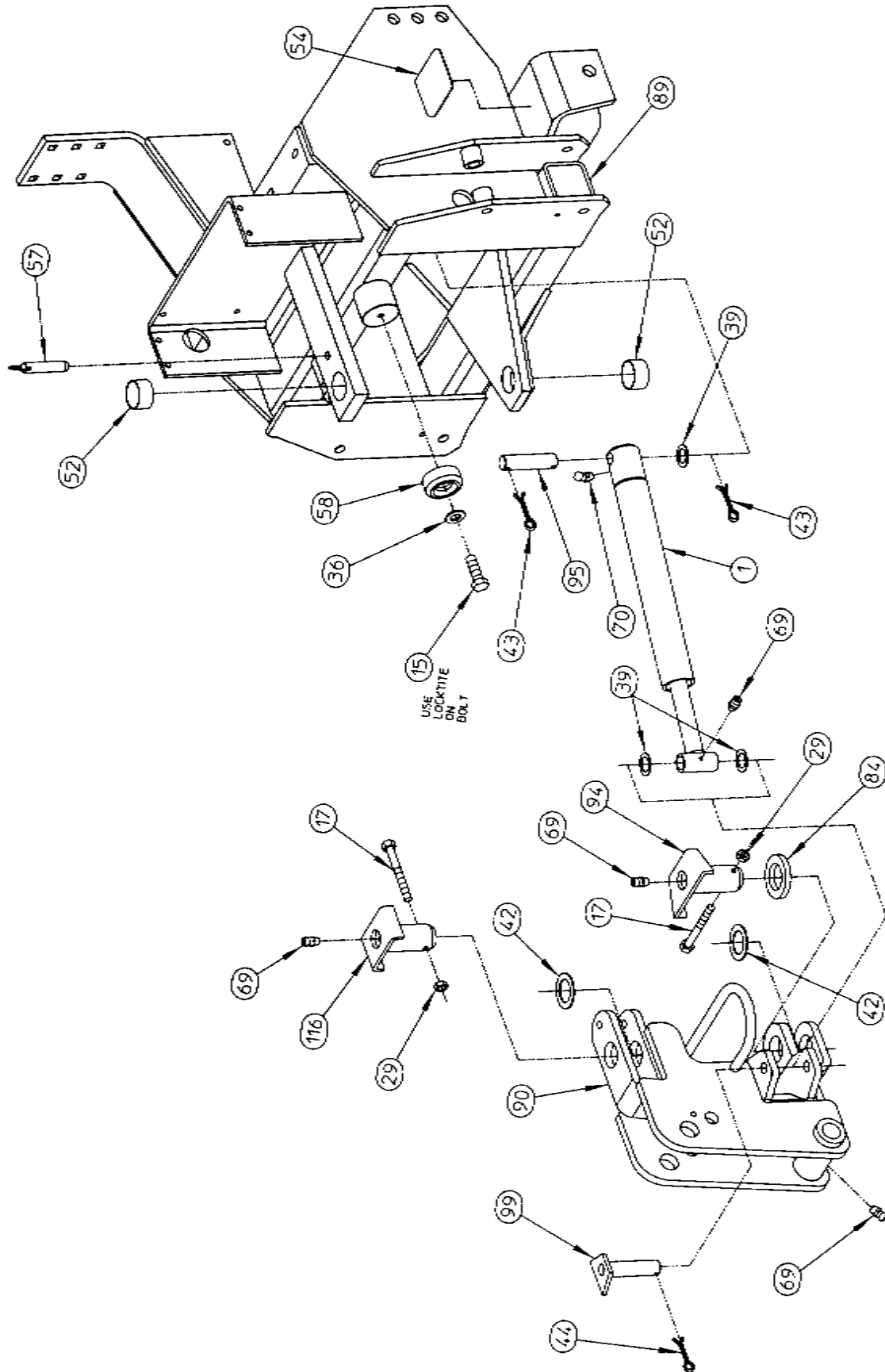

BOOM, DIPPERSTICK, AND BUCKET AREA

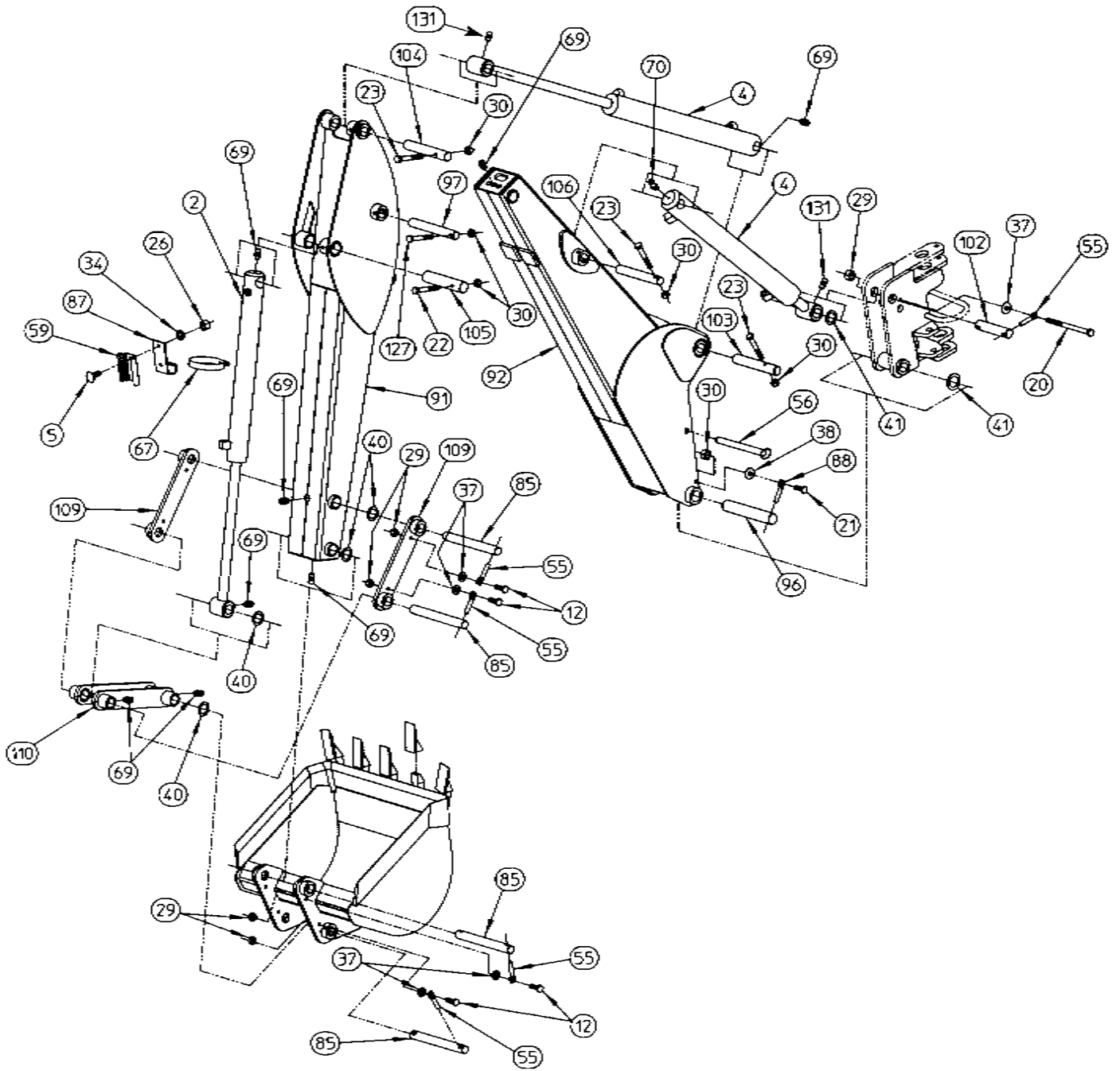

HYDRAULIC PLUMBING

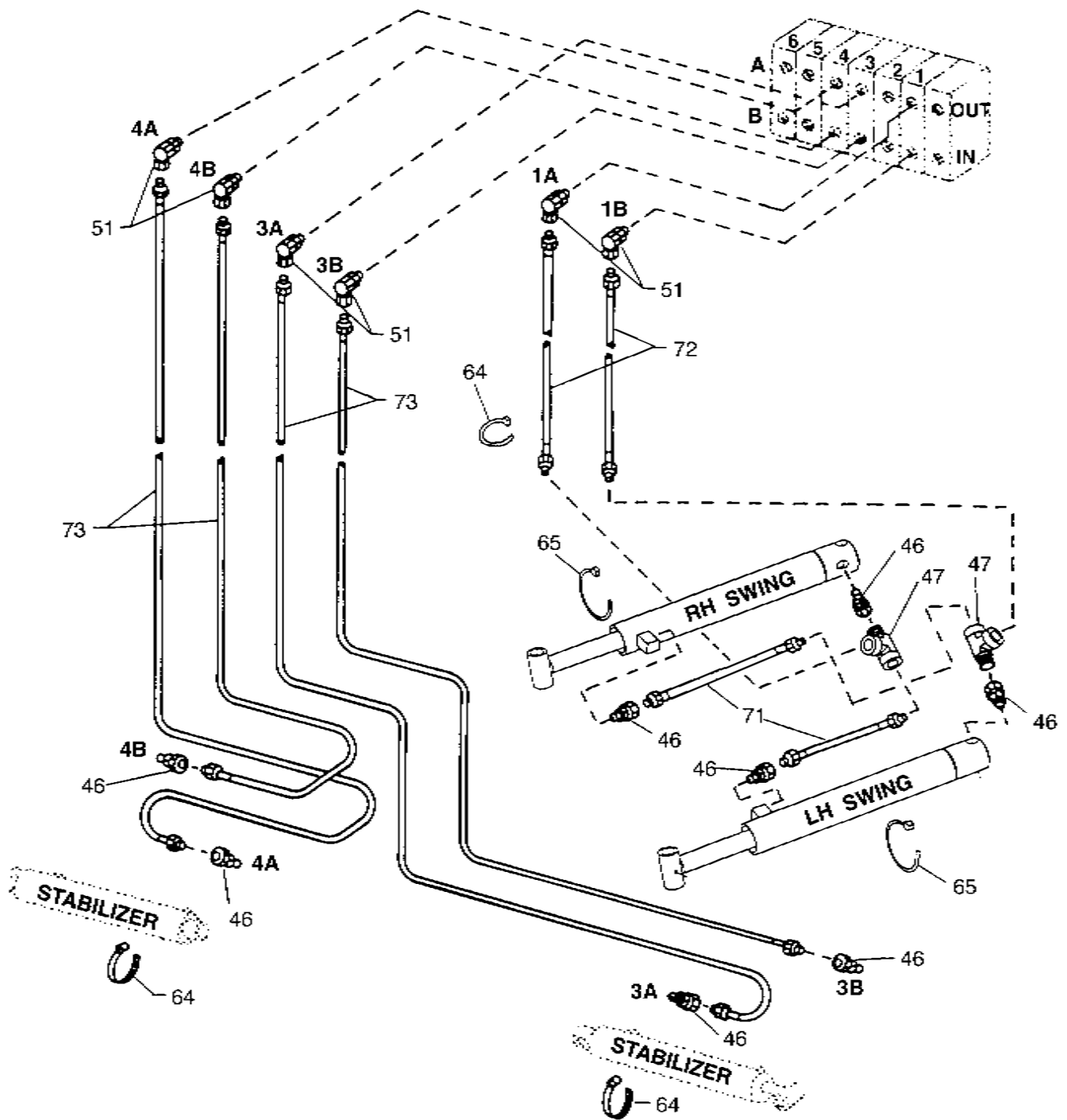

HYDRAULIC PLUMBING

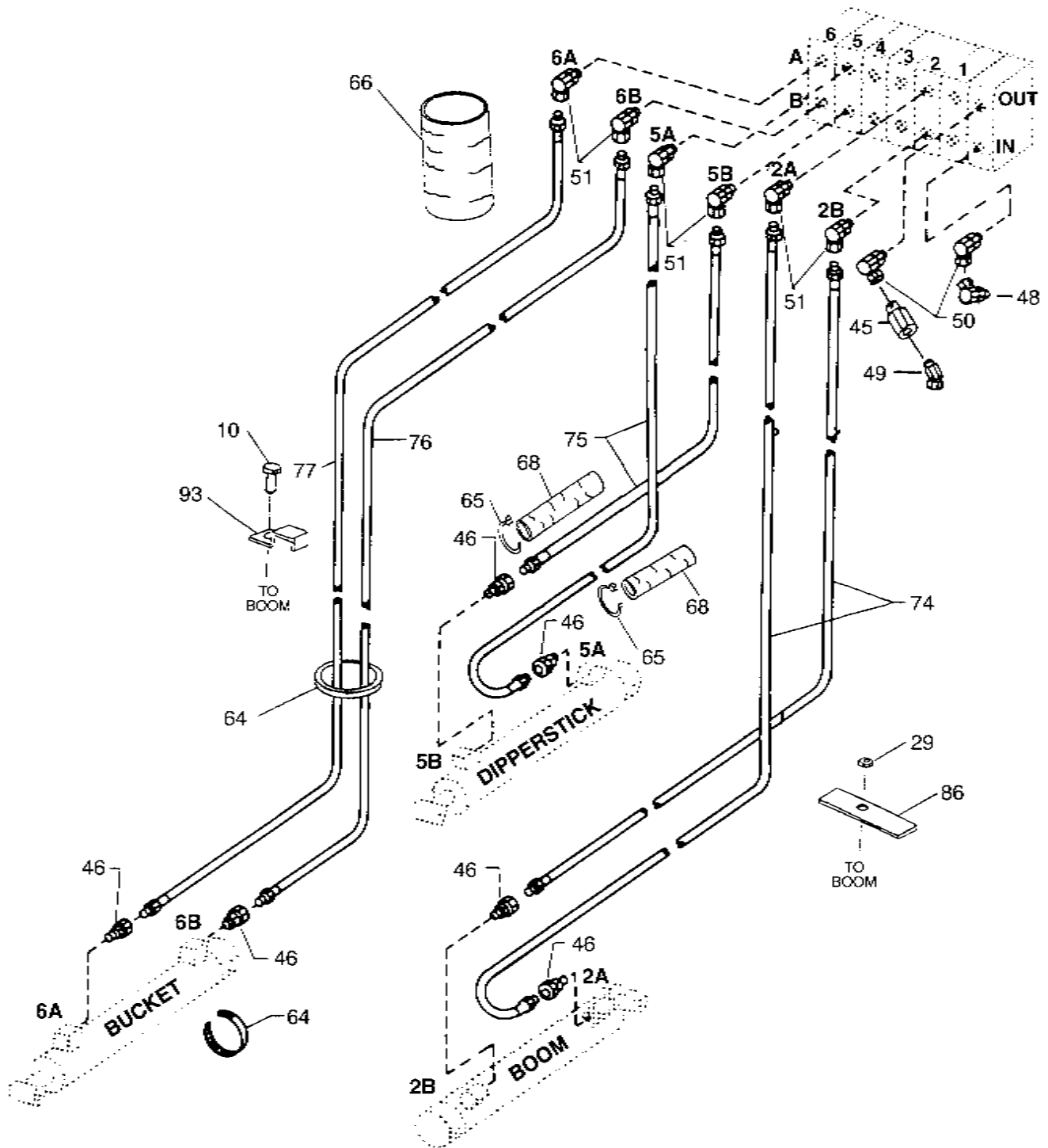

HYDRAULIC CYLINDERS - PARTS LIST

(7-1/2 FOOT BACKHOE)

Index	Description	187:	188:	189:	192:
1	Locknut, 3/4 NF Nyloc	7574	7574		
2	Nut, 7/8 NF Nyloc				7609
3	Jamnut, Lock 1" NF			7712	
4	Wiper Seal	*	*	*	*
5	O-Ring, 1-1/2" OD x 1-5/16" ID	*			
6	Step Seal				*
7	U-Cup Seal				*
8	O-Ring, 1-3/4" OD x 1-1/2" ID	*			
9	Rod Seal	*	*		
10	O-Ring, 3/4 OD x 9/16 ID	*			
11	O-Ring, 2-9/16 OD x 2-3/8 ID				*
12	O-Ring, 1" OD x 3/4 ID			*	
13	O-Ring, 1-3/8 OD x 1-1/8 ID			*	
14	O-Ring, 2" OD x 1-3/4 ID		*	*	
15	O-Ring, 2" OD x 1-5/8 ID			*	
16	Back-Up Ring				*
17	Back-Up Ring, 1-3/8 OD x 1-1/8 ID			*	
18	Back-Up Ring, 2" OD x 1-3/4 ID		*	*	
19	Back-Up Ring, 2" OD x 1-5/8 ID			*	
20	Wear Ring				*
21	Back-Up Ring, 1-3/4" OD x 1-1/2" ID	*			
22	Piston Ring	*			
23	Bronze Bearing, 7/8 OD x 3/4 ID x 1"	11974			
24	Retaining Ring, Internal	*		*	
25	Piston, with O-Ring and Back-Up	903160			
26	Gland			904232	
27	Cylinder Tube Weldment	903145	904755	904775	908090
28	Piston Rod Weldment	903155	904765	904785	908100
29	Gland with O-Rings, Back-Ups, & Wear Rings	903165	904800		908110
30	Gland Nut		904727		
31	Piston		11684	904231	11688
32	For Complete Cylinder, order	187	188	189	192
33	Seal Repair Kit for One Cylinder	903175	904795	904260	908085

*Not available as a separate repair part - order Seal Repair Kit.

IMPORTANT - Replace cylinder nut (1, 2, 3) any time nut must be removed, and torque to proper value shown.

Cylinder Data:

CYLINDER	PISTON DIA.	STROKE	RETRACTED LENGTH	EXTENDED LENGTH	ROD DIA.	PIVOT PIN DIA.	TYPE OF ACTION
*192 - BOOM	2 1/2"	18 1/2"	26 1/2"	45 1/2"	1 1/2"	1 1/2"	DA
*192 - DIPPER	2 1/2"	18 1/2"	26 1/2"	45 1/2"	1 1/2"	1 1/2"	DA
188 - BUCKET	2"	15 1/2"	22 1/2"	38 1/2"	1 1/2"	1"	DA
189 - STABILIZER	2"	11 1/2"	17"	28 1/2"	1 1/2"	3/4"	DA
187 - SWING	1 3/4"	8 3/4"	15 1/2"	23 1/2"	1"	3/4"	DA

*Identical cylinders used for both functions.

HYDRAULIC CYLINDERS

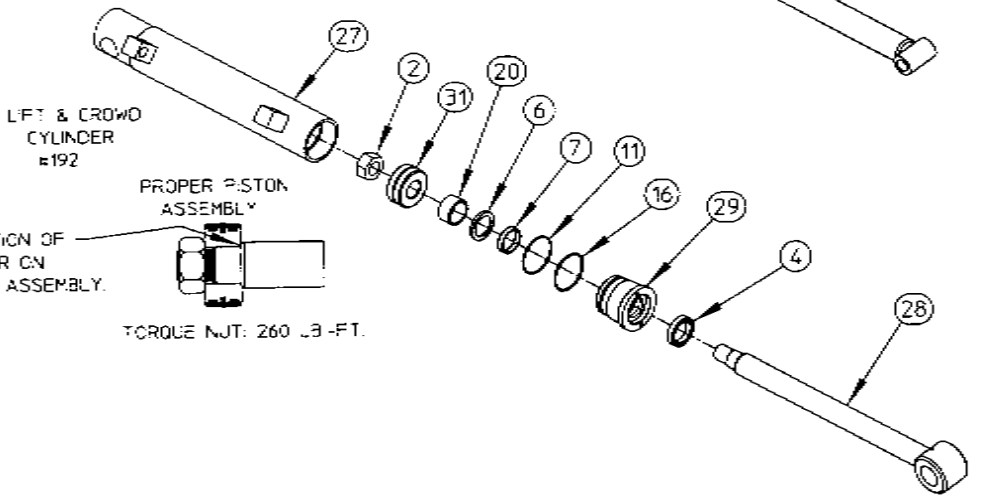
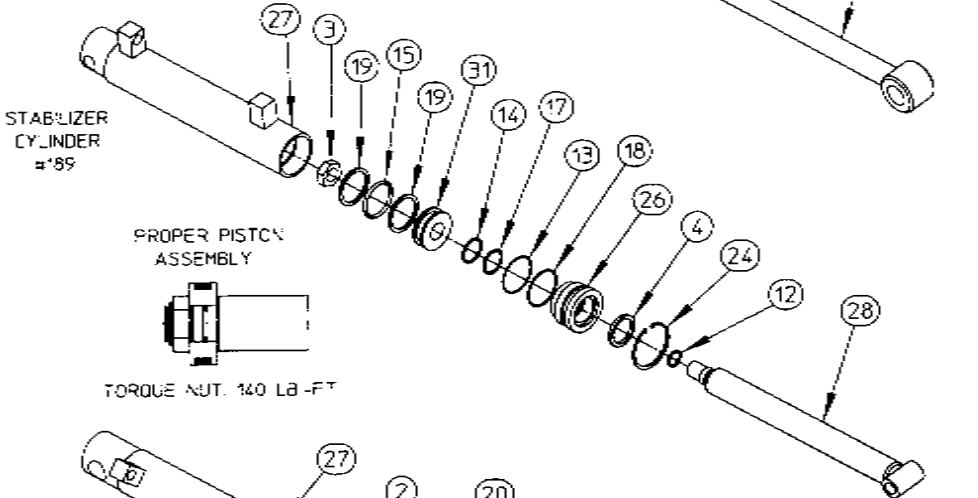
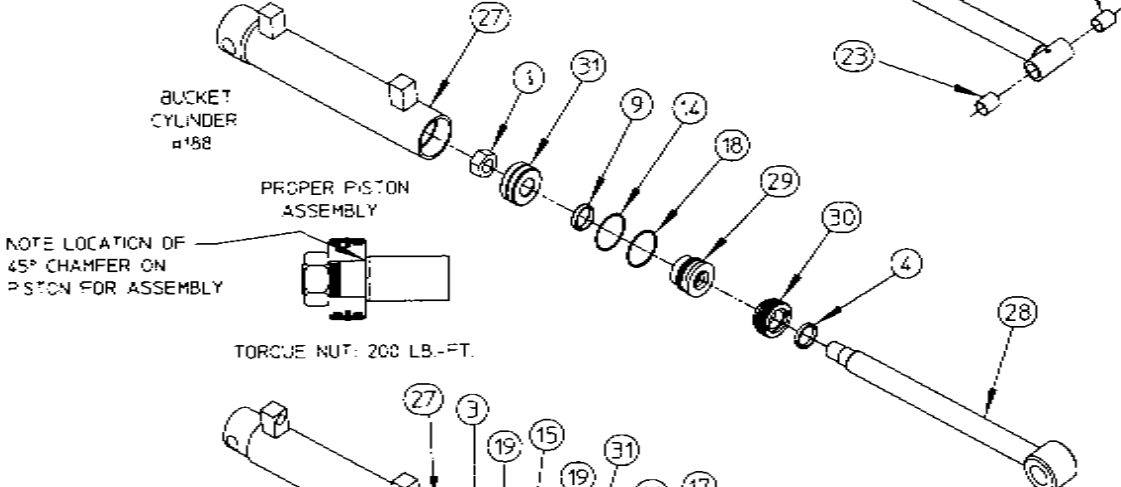
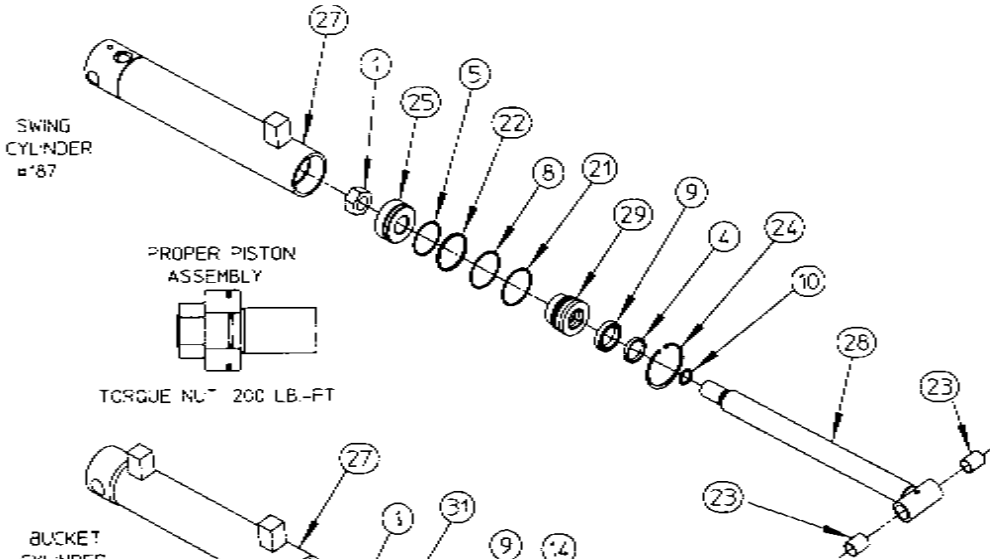

BACKHOES - DIMENSIONS AND SPECIFICATIONS

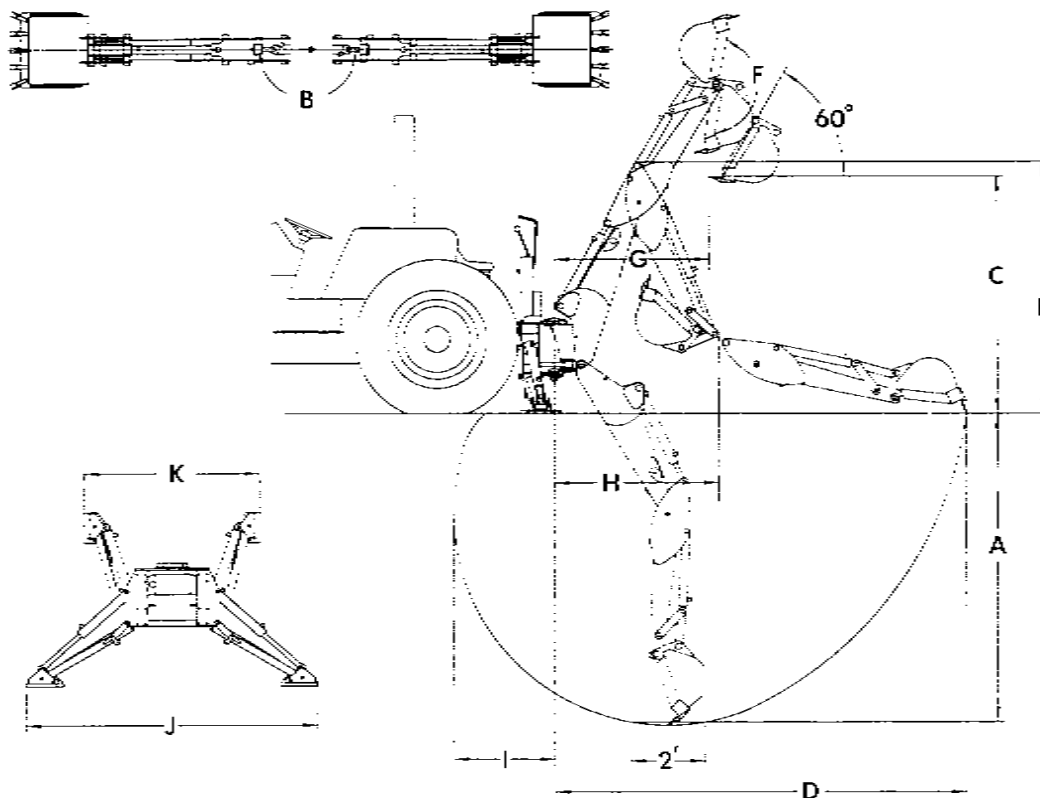

SERIES



Maximum Digging Depth	8'0"
A. Digging Depth (two foot flat bottom)	7'6"
B. Swing Arc	180°
C. Loading Height (bucket at 60°)	5'10"
D. Reach from Center Line of Swing Pivot	9'6"
E. Transport Height (maximum)	5'9"
F. Bucket Rotation	180°
G. Loading Reach (bucket at 60°)	3'7"
H. Transport Overhang	3'6"
I. Undercut	2'6"
J. Stabilizer Spread, down position	7'5"
K. Stabilizer Spread, up position	5'1"
Bucket Cylinder Digging Force	2840 lbs.
Dipperstick Cylinder Digging Force	2005 lbs.
Shipping Weight (less bucket)	875 lbs.
Hydraulic Volume Requirements	5 to 6 GPM
Hydraulic Pressure Requirements	2250 psi.
Recommended Tractor HP Requirements	25 - 45 HP

Specifications May Vary Depending on Tractor Model and are Subject to Change Without Notification. Tractors Must Be Equipped with ROPS and Seat belt That Will Provide Better Safety.

TORQUE VALUES

Common bolts and nuts

Tightening Torque Plus/Minus 20%

Size	Grade 2 	Grade 5 	Grade 8 
1/4-20 NC	70 in. lbs.	115 in. lbs.	165 in. lbs.
1/4-28 NF	85 in. lbs.	140 in. lbs.	200 in. lbs.
5/16-18 NC	150 in. lbs.	250 in. lbs.	350 in. lbs.
5/16-24 NF	165 in. lbs.	270 in. lbs.	30 ft. lbs.
3/8-16 NC	260 in. lbs.	35 ft. lbs.	50 ft. lbs.
3/8-24 NF	300 in. lbs.	40 ft. lbs.	60 ft. lbs.
7/16-14 NC	35 ft. lbs.	55 ft. lbs.	80 ft. lbs.
7/16-20 NF	45 ft. lbs.	75 ft. lbs.	105 ft. lbs.
1/2-13 NC	50 ft. lbs.	80 ft. lbs.	115 ft. lbs.
1/2-20 NF	70 ft. lbs.	105 ft. lbs.	165 ft. lbs.
9/16-12 NC	75 ft. lbs.	125 ft. lbs.	175 ft. lbs.
9/16-18 NF	100 ft. lbs.	165 ft. lbs.	230 ft. lbs.
5/8-11 NC	110 ft. lbs.	180 ft. lbs.	260 ft. lbs.
5/8-18 NF	140 ft. lbs.	230 ft. lbs.	330 ft. lbs.
3/4-10 NC	150 ft. lbs.	245 ft. lbs.	350 ft. lbs.
3/4-16 NF	200 ft. lbs.	325 ft. lbs.	470 ft. lbs.

Note - See tractor instruction manual or your tractor dealer for tightening of metric bolts.

CONTROL VALVE SECTION

Typical Section for Actuate (Bucket) & Swing Circuits

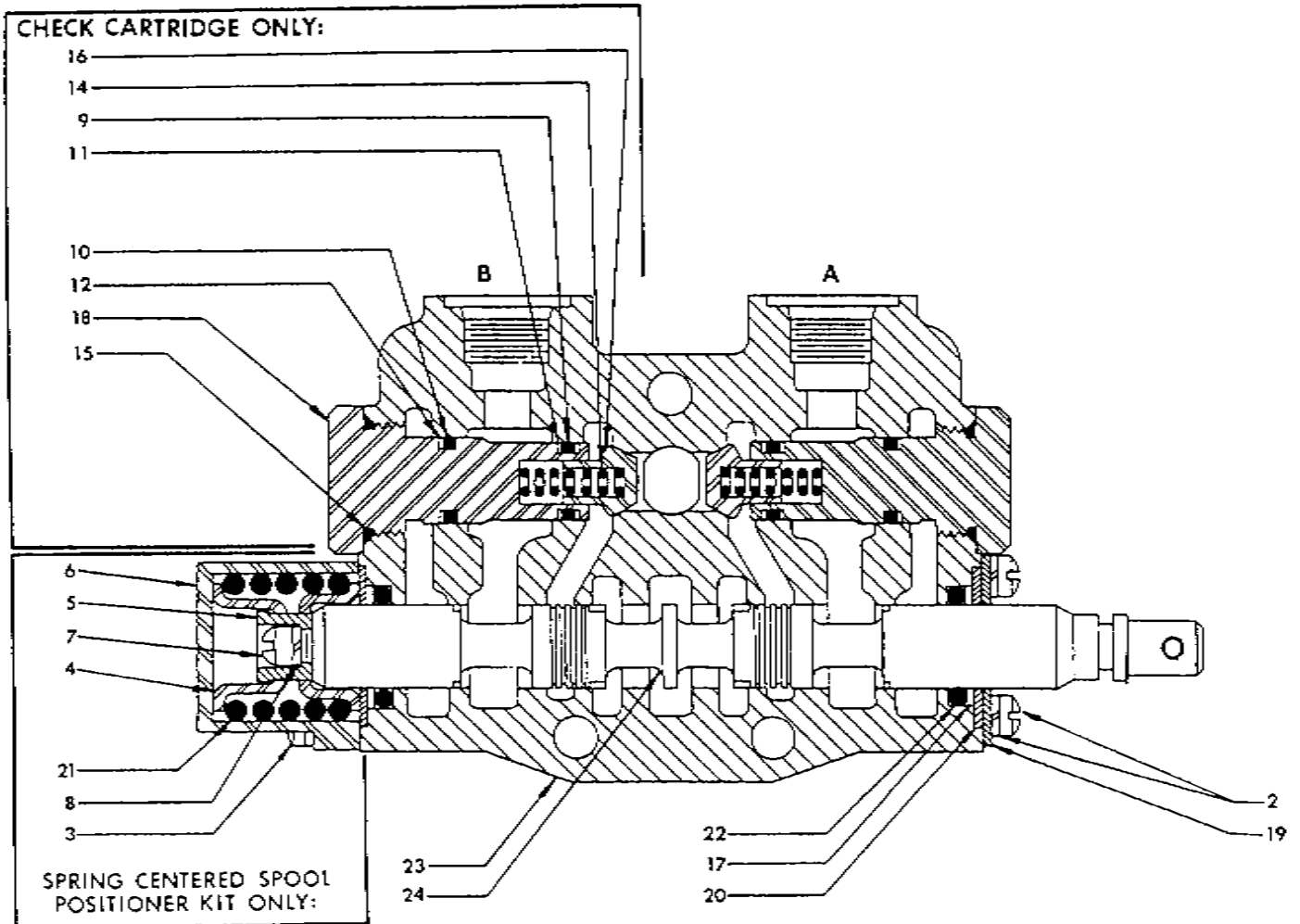

CONTROL VALVE SECTION

Typical Section for Actuate (Bucket) & Swing Circuits

Ref. No	Part No.	Qty.	Description	Part No.	Qty.	Description
2	*	2	Machine screw & lockwasher	23073	1	Control valve section-Actuate (bucket) and swing circuits consisting of above listed parts.
3	***	2	Bonnet screw			
4	***	2	Stop collar			
5	***	1	Spool collar	10257	2	<i>NOTE: Two orifice plates (.062") must be added to complete swing section.</i>
6	***	1	Bonnet	10315	1	Control valve section seal kit - Actuate (bucket) and swing circuits, consisting of: (2) #22, (2) #9, (2) #10, (4) #11, (2) #12, (2) #15, (2) pressure section seal, and (2) exhaust section seal.
7	***	1	Spool assembly screw			
8	***	1	Spool asmy. screw lockwasher			
9	**	2	Check plug O-ring seal (inner)	10316	1	Spool seal kit, consisting of: (2) #22 & (2) #17.
10	**	2	Check plug O-ring seal (outer)	10305	2	Check cartridge, as shown.
11	**	4	Back-up washer (inner)	10313	2	Check cartridge seal kit, consisting of: (1) #9, (1) #10, (2) #11, (1) #12, and (2) #15.
12	**	2	Back-up washer (outer)	10107	1	Spring centered spool positioner kit, as shown.
14	*	2	Lift check spring			
15	**	2	Lift check spring O-ring seal			
16	*	2	Lift check poppet			
17	**	2	Back-up washer			
18	*	2	Lift check plug			
19	10321	1	Seal plate retainer			
20	10322	2	Seal retainer			
21	***	1	Centering spring			
22	**	2	Spool O-ring seal			
23	*	1	Center section housing			
24	*	1	Four-way spool			

* Not available as a separate repair part, order complete section or cartridge.

** Not available as a separate repair part, order seal kit.

*** Not available as a separate repair part, order spool positioner kit as shown.

CONTROL VALVE SECTION

Typical Section for Crowd Circuit

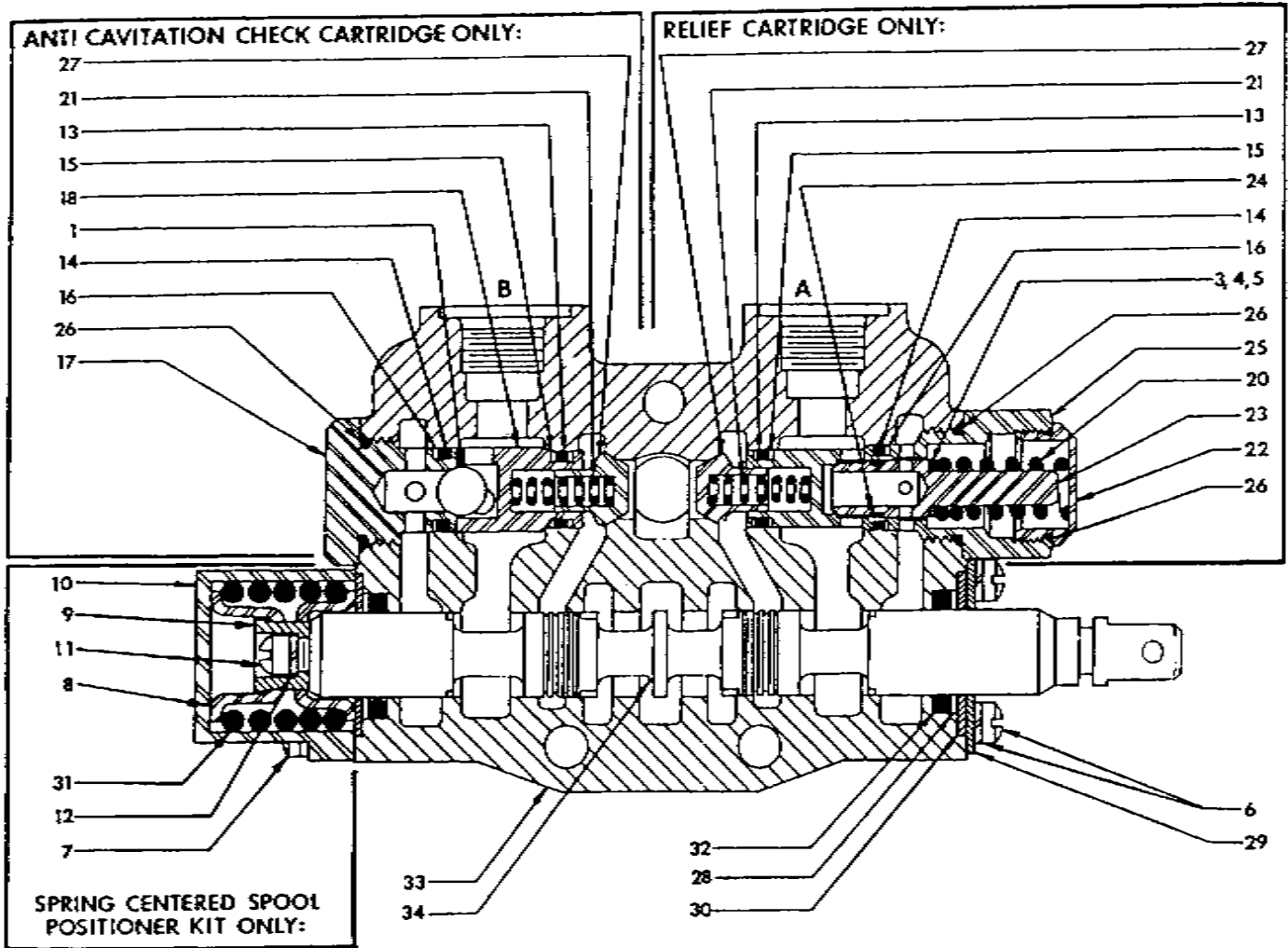

CONTROL VALVE SECTION

Typical Section for Crowd Circuits

Ref. No.	Part No.	Qty.	Description	Ref. No.	Part No.	Qty.	Description
1	*	1	7/16" Steel ball	20	*	1	Spring (2001-3000 PSI crack)
3,4,5	*	A/R	Shim (.010", .020", .040" thick)	21	*	2	Check spring
6	*	2	Machine screw & lockwasher	22	*	1	Relief cap
7	***	2	Bonnet screw	23	**	1	Relief poppet
8	***	2	Stop collar	24	**	1	Piston ring
9	***	1	Spool collar	25	*	1	Relief body
10	***	1	Bonnet	26	**	2	O-Ring seal
11	***	1	Spool asmy. screw	27	*	2	Steel check
12	***	1	Spool asmy. screw lockwasher	28	**	2	Back-up washer
13	**	2	O-Ring seal (inner)	29	10321	1	Seal plate retainer
14	**	2	O-Ring seal (outer)	30	10322	2	Seal retainer
15	**	4	Back-up washer (inner)	31	***	1	Centering spring
16	**	2	Back-up washer (outer)	32	**	2	Spool O-Ring seal
17	*	1	Anti-cavitation check body	33	*	1	Center section housing
18	*	1	Check ball retainer	34	*	1	Four-way spool

Part No.	Qty.	Description
23076	1	Control Valve Section - Crowd Circuit, consisting of above listed parts.
10315	1	Control Valve Section Seal Kit - Crowd Circuit, consisting of: (2) #32, (2) #13, (2) #14, (4) #15, (2) #16, (2) #26, (2) pressure section seal, and (2) exhaust section seal.
10316	1	Spool Seal Kit, consisting of: (2) #32 and (2) #28.
10303	1	Relief Cartridge (2500 PSI) as shown.
10313	1	Relief Cartridge Seal Kit, consisting of: (1) #13, (1) #14, (2) #15, (1) #16, and (2) #26.
10177	1	Poppet Seal Kit, consisting of: (1) #23 and (1) #24.
10304	1	Anti-Cavitation Check Cartridge, as shown.
10313	1	Anti-Cavitation Check Seal Kit, same as Relief Cartridge Seal Kit listed above.
10107	1	Spring Centered Spool Positioner Kit, as shown.

* Not available as a separate repair part, order complete section or cartridge.

** Not available as a separate repair part, order seal kit.

*** Not available as a separate repair part, order spool positioner kit.

CONTROL VALVE SECTION

Typical Section for Lift Circuits

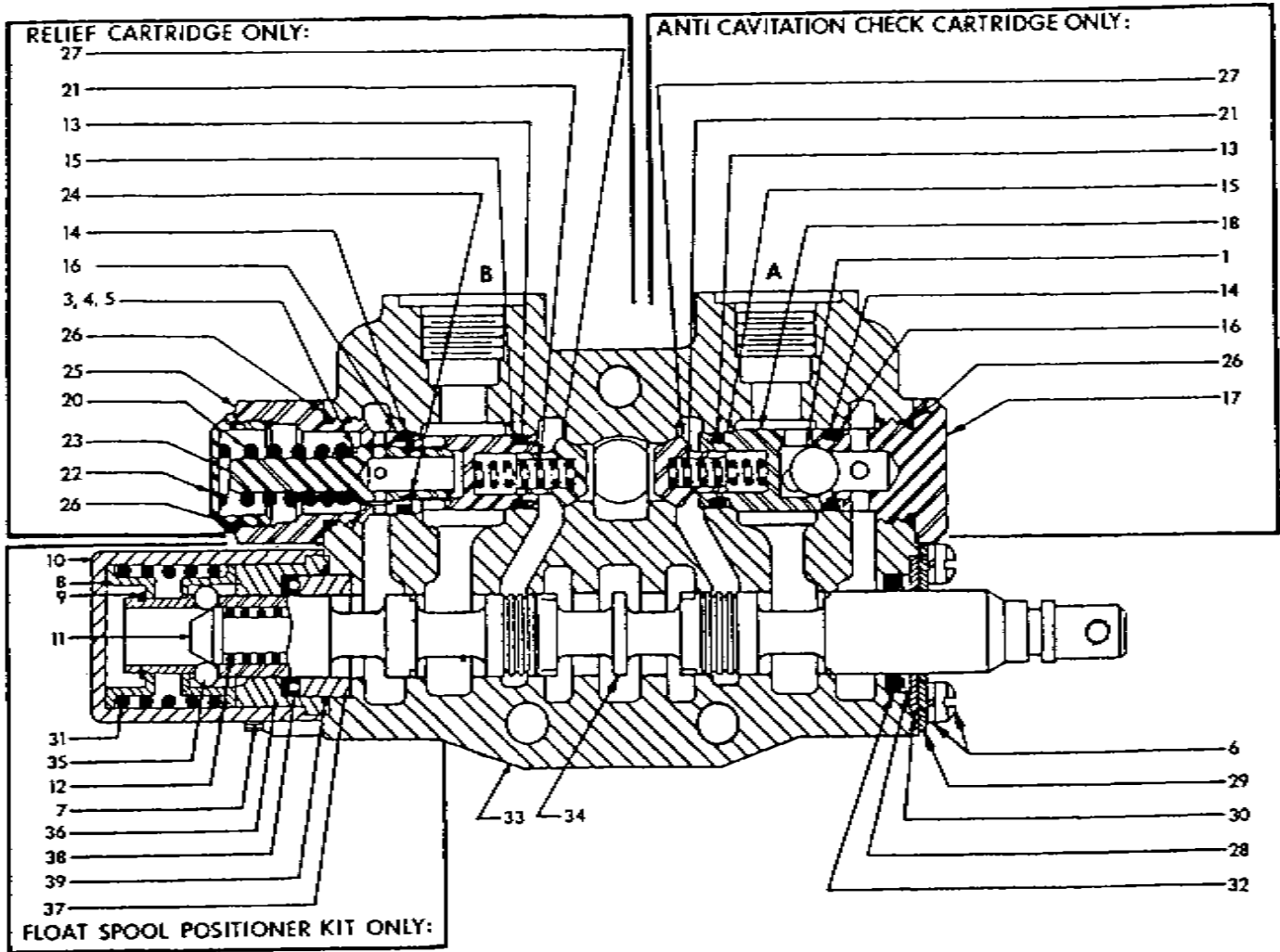

CONTROL VALVE SECTION

Typical Section for Lift Circuits

Ref. No.	Part No.	Qty.	Description	Ref. No.	Part No.	Qty.	Description
1	*	1	7/16" Steel ball	23	**	1	Relief poppet
3,4,5	*	A/R	Shim (.010", .020", .040" thick)	24	**	1	Piston ring
6	*	2	Machine screw & lockwasher	25	*	1	Relief body
7	***	2	Bonnet screw	26	*	3	O-Ring seal
8	***	2	Stop collar	27	*	2	Steel check
9	***	1	Retaining ring	28	**	2	Back-up washer
10	***	1	Bonnet	29	10321	1	Seal plate retainer
11	***	1	Detent ball follower	30	10322	2	Seal retainer
12	***	1	Detent spring	31	***	1	Centering spring
13	**	2	O-Ring seal (inner)	32	**	2	Spool O-Ring seal
14	**	2	O-Ring seal (outer)	33	*	1	Center section housing
15	**	4	Back-up washer (inner)	34	*	1	Four-way spool
16	**	2	Back-up washer (outer)	35	***	4	Detent ball
17	*	1	Anti-cavitation check body	36	***	1	Float sleeve
18	*	1	Check ball retainer	37	***	1	Retaining sleeve
20	*	1	Spring (2001-3000 PSI crack)	38	**	1	U-cup seal
21	*	2	Check spring	39	**	1	O-Ring seal
22	*	1	Relief cap				

Part No.	Qty.	Description
23079	1	Control Valve Section - Lift Circuit, consisting of above listed parts. Note, one orifice plate (.062") must be added to "A" port to complete lift section.
10516	1	Control Valve Section Seal Kit - Lift Circuit, consisting of: (1) #32, (2) #13, (2) #14, (1) #28, (1) #38, (1) #39, (4) #15, (2) #16, (2) #26, (2) pressure section seal, and (2) exhaust section seal.
10517	1	Spool Seal Kit, consisting of: (1) #32, (1) #28, (1) #38, and (1) #39.
10303	1	Relief Cartridge (2500 PSI) as shown.
10313	1	Relief Cartridge Seal Kit, consisting of: (1) #13, (1) #14, (2) #15, (1) #16, and (2) #26.
10177	1	Poppet Seal Kit, consisting of: (1) #23 and (1) #24.
10304	1	Anti-Cavitation Check Cartridge, as shown.
10313	1	Anti-Cavitation Check Seal Kit, same as Relief Cartridge Seal Kit listed above.
10518	1	Float Spool Positioner Kit, as shown.
10257	1	Restrictor - .062".

* Not available as a separate repair part, order complete section or cartridge.

** Not available as a separate repair part, order seal kit.

*** Not available as a separate repair part, order spool positioner kit.

CONTROL VALVE SECTION

Typical Section for Actuate Stabilizer Circuits

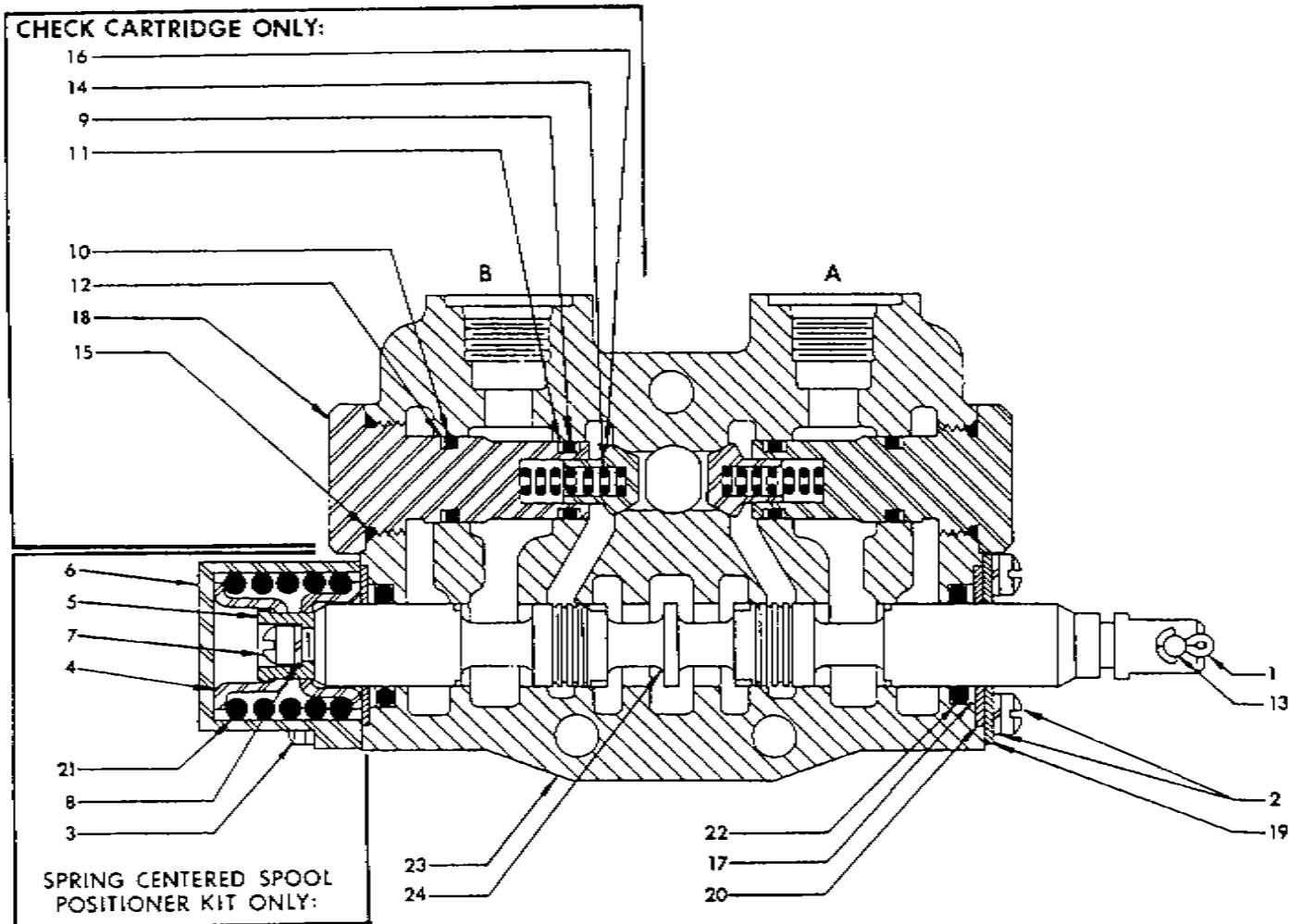

CONTROL VALVE SECTION

Typical Section for Actuate Stabilizer Circuits

Ref. No	Part No.	Qty.	Description	Part No.	Qty.	Description
1	8554	1	Handle cotter pin, 3/32 x 3/4	10156	1	Control valve section - Actuate Stabilizer circuits consisting of above listed parts.
2	*	2	Machine screw & lockwasher	10315	1	Control valve section seal kit - Actuate stabilizer circuits, consisting of: (2) #22, (2) #9, (2) #10, (4) #11, (2) #12, (2) #15, (2) pressure section seal, and (2) exhaust section seal.
3	***	2	Bonnet screw	10316	1	Spool seal kit, consisting of: (2) #22 & (2) #17.
4	***	2	Stop collar	10305	2	Check cartridge, as shown.
5	***	1	Spool collar	10313	2	Check cartridge seal kit, consisting of: (1) #9, (1) #10, (2) #11, (1) #12, and (2) #15.
6	***	1	Bonnet	10107	1	Spring centered spool positioner kit, as shown.
7	***	1	Spool assembly screw			
8	***	1	Spool army. screw lockwasher			
9	**	2	Check plug O-ring seal (inner)			
10	**	2	Check plug O-ring seal (outer)			
11	**	4	Back-up washer (inner)			
12	**	2	Back-up washer (outer)			
13	13436	1	Handle clevis pin, 1/4 dia. x 7/8			
14	*	2	Lift check spring			
15	**	2	Lift check spring O-ring seal			
16	*	2	Lift check poppet			
17	**	2	Back-up washer			
18	*	2	Lift check plug			
19	10321	1	Seal plate retainer			
20	10322	2	Seal retainer			
21	***	1	Centering spring			
22	**	2	Spool O-ring seal			
23	*	1	Center section housing			
24	*	1	Four-way spool			

* Not available as a separate repair part, order complete section or cartridge.

** Not available as a separate repair part, order seal kit.

*** Not available as a separate repair part, order spool positioner kit as shown.

MAIN SYSTEM RELIEF VALVE (2100 PSI)

Location: Left Hand Valve Cover

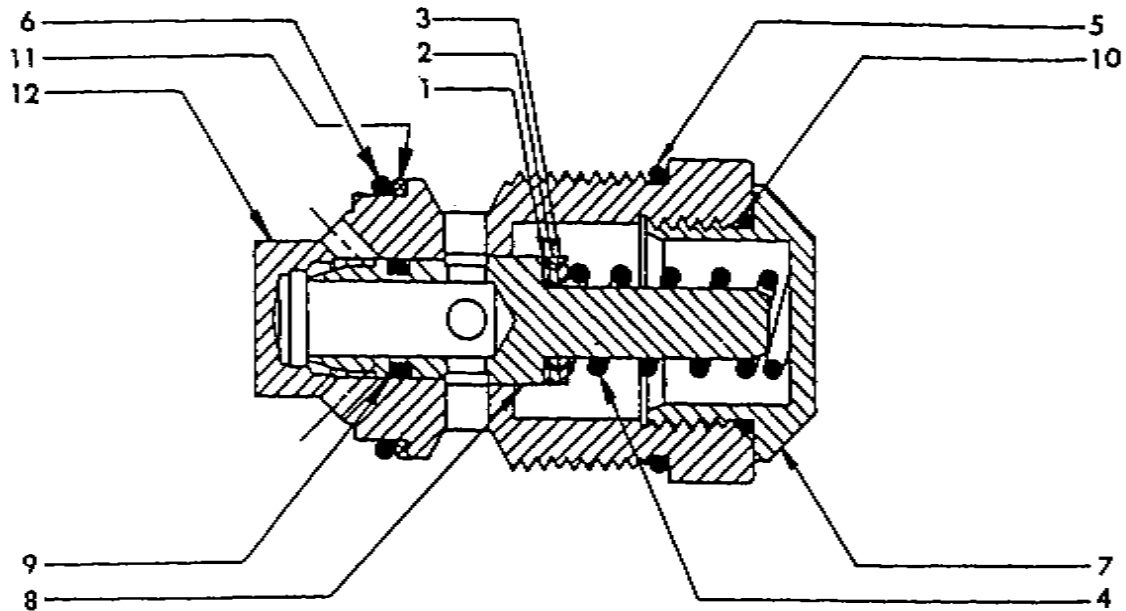

Ref. No.	Part No.	Qty.	Description
1	*	1	Shim, .040 thick
2	*	A/R	Shim, .020 thick
3	*	1	Shim, .010 thick
4	*	1	Spring (1751-2200 PSI crack)
5	**	1	O-Ring seal
6	**	1	O-Ring seal
7	*	1	Relief Cap
8	**	1	Relief poppet
9	**	1	Piston ring
10	**	1	O-Ring seal
11	**	2	Back-up washer
12	*	1	Body
	23036	1	Main system relief valve, consisting of above listed parts
	10172	1	Seal and service kit, consisting of: (1) #5, (1) #6, (1) #8, (1) #9, (1) #10, and (1) #11

* Not available as a separate repair part, order complete main system relief valve.

** Not available as a separate repair part, order seal and service kit.

Part No.	Qty.	Description
23037	1	Left hand end cover with main relief valve
10160	1	Tie rod kit (six spool) contains three studs and three stud nuts
10176	1	Valve seal kit, containing all O-Rings and back-up rings for a six spool valve
23062	1	Six spool valve
10308	1	Right hand end cover
23023	1	Section seal kit

SERVICE NOTES:

SERVICE NOTES:

SERVICE NOTES:



**be careful.....
avoid accidents**