

# OPERATOR'S MANUAL

# model 80A backhoe

THIS MANUAL INCLUDES:  
W395 BASIC BACKHOE

- W215 - BUCKET, 9"
- W216 - BUCKET, 13"
- W217 - BUCKET, 16"
- W218 - BUCKET, 19"
- W219 - BUCKET, 24"
- W208 - BUCKET, 36"

SERIAL NO. <sup>2524</sup>~~2338~~ AND LATER



THIS SAFETY ALERT SYMBOL  
IDENTIFIES IMPORTANT SAFETY  
MESSAGES IN THIS MANUAL.



**AMEREGUIP CORPORATION**

---

1015 CALUMET AVENUE  
KIEL, WISCONSIN 53042  
414-894-7063

# CONTENTS

---

Safety Precautions.....	2 - 4
Basic Assembly Instructions.....	5 - 7
General Operation.....	7 - 12
Service.....	13, 14
Removal from Tractor and Storage.....	15
Hydraulic Trouble Shooting.....	16 - 19
Valve Repair - Disassembly.....	20, 21
Control Valve.....	22 - 28
Backhoe - Valve Mount, Controls, and Seat.....	29
Backhoe - Boom, Dipperstick, and Bucket.....	30, 31
Torque Chart.....	31
Backhoe - Swing Frame.....	32
Backhoe - Mainframe and Stabilizers.....	33
Hose Diagrams.....	34, 35
Hydraulic Cylinders.....	36, 37
Specifications.....	38, 39
Purchase and Service Record.....	40

# SAFETY PRECAUTIONS

---



## ATTENTION! BECOME ALERT! YOUR SAFETY IS INVOLVED!

This symbol is used to call your attention to safety precautions that should be followed by the operator to avoid accidents. When you see this symbol - HEED ITS WARNING!

Failure to follow the safety messages and instructions shown in this manual may result in serious injury or death.

Many hours of lost time and much suffering is caused by the failure to practice simple safety rules.

**IT IS TOO LATE TO REMEMBER WHAT SHOULD HAVE BEEN DONE AFTER THE ACCIDENT HAS HAPPENED.**

### BACKHOE SAFETY PRECAUTIONS:

Accidents can be avoided if the following safety rules are observed:

#### Preparation:

DO NOT operate the backhoe unless it is rigidly attached to the tractor.

KNOW YOUR controls. Read this operator's manual and the manual provided with your tractor. Learn how to stop the tractor, the engine, and the backhoe quickly in an emergency.

PROVIDE adequate front end weight to counter-balance the backhoe at all times. 20% of the total tractor, loader, and backhoe weight must be on the tractor front axle. If unsure of weight distribution, determine at a weigh scale.

BE SURE the area is clear of overhead or underground utilities or other hazards.

POSITION a barricade around the work area.

KEEP ALL bystanders a safe distance away.

#### Operation:

DO NOT attempt to enter operator's platform of backhoe by using stabilizers as a step.

OPERATE from the backhoe operator's seat only.

ALLOW only one person to operate the backhoe at any time.

DISENGAGE safety locks as shown in Fig 3, before attempting to operate the backhoe.

NEVER dig with the backhoe unless the stabilizers are properly set.

DO NOT dig under stabilizers or tractor-backhoe. Soft ground or sandy soil can cause cave-ins.

KEEP BUCKET away from stabilizer area to avoid possible stabilizer damage.

ALWAYS swing bucket uphill to dump when on a hillside and keep loaded bucket low.

SET BRAKES and block wheels when operating on hills and banks to avoid dangerous run-away.

WATCH for overhead wires. DO NOT touch wires with any part of the backhoe.

NEVER allow a person to work under a raised bucket.

NEVER lift a person with the backhoe.

DO NOT use the backhoe bucket as a battering ram. Use the backhoe only for digging.

ALWAYS lower the backhoe bucket and stabilizers to the ground, shut off engine, and apply the parking brake before getting off unit, or when not digging.

NEVER leave the tractor unattended with the engine running.

DO NOT attempt to raise the tractor off the ground or move the tractor forward or backward using the backhoe dipperstick or bucket.

#### Transportation:

ALWAYS engage safety locks before transporting backhoe. See Fig 3, page 7.

DO NOT drive the tractor near the edge of a ditch or excavation.

ALWAYS use accessory lights and devices, when transporting on a road or highway, to warn operators of other vehicles. Check your local government regulations.

BE SURE that the SMV emblem is visible to the rear.

## Adjustments and Inspection:

CHECK pins that attach backhoe to tractor and all pivot pins for tightness several times daily. Replace any parts which are bent, broken, or missing.

ALWAYS engage safety locks before servicing backhoe. See Fig 3, page 7.

DO NOT oil, grease, or adjust the backhoe while it is in motion. For greasing see Service section for details.

DO NOT change any backhoe relief valve settings. They are factory set for best backhoe performance and safety.

PROTECT YOUR EYES - WEAR SAFETY GLASSES.

GUARD AGAINST INJURY when driving connecting pins or performing any repair in which particles can chip from work piece or striking tool.

DO NOT REMOVE ANY GUARDS on backhoe or tractor.

### AVOID HIGH-PRESSURE FLUIDS

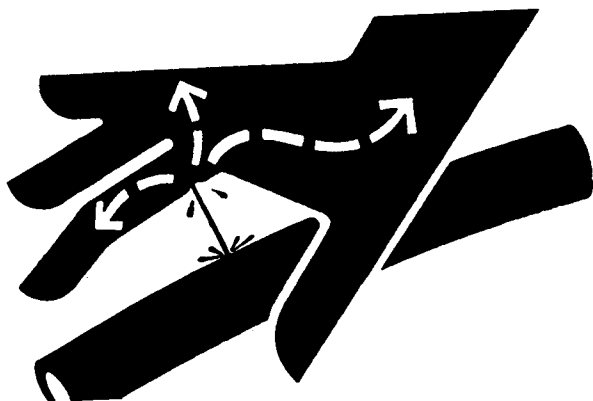

ESCAPING FLUID under pressure can have sufficient force to penetrate the skin and cause serious injury. Be sure to stop engine and relieve all pressure before disconnecting lines. Be sure all connections are tight and that lines, pipes, and hoses are not damaged before applying pressure to the system.

FLUID ESCAPING from a very small hole can be almost invisible. Use a piece of cardboard or wood - not your hands - to search for suspected leaks.

SEE A DOCTOR AT ONCE if injured by escaping fluid. Serious infection or gangrene can develop if proper medical treatment is not administered immediately.

## SAFETY DECALS

**!** The safety of the operator was a prime consideration in the design of this backhoe. Proper shielding, convenient controls, simple adjustments, and other safety features have been built into this backhoe.

The following decals are located on the backhoe. Keep decals clean, and replace them immediately if they are missing, damaged, or no longer readable. Contact your Dealer or Amerequip for replacements.

**!** **DANGER**

**CRUSHING  
HAZARD**

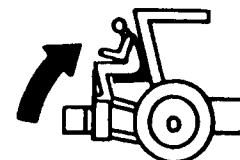

DO NOT OPERATE 3-POINT RIGID MOUNT BACKHOE UNLESS HITCH AND STABILIZER BARS ARE INSTALLED PROPERLY. FAILURE TO DO SO MAY RESULT IN SERIOUS INJURY OR DEATH FROM BACKHOE BEING THRUST UPWARD BY DIGGING FORCES - CRUSHING OPERATOR.

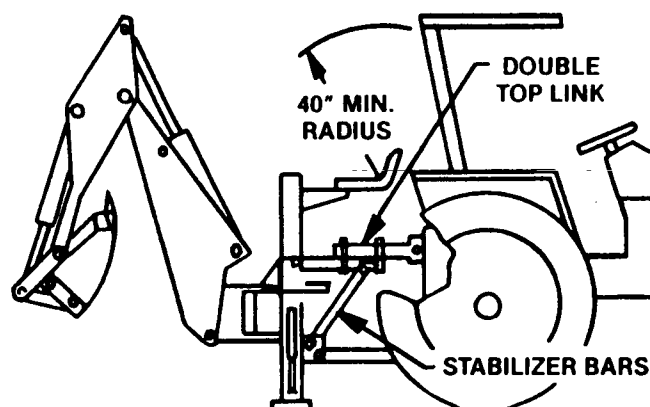

USE ONLY SPECIAL HITCH PARTS SUPPLIED WITH BACKHOE. SEE OPERATOR'S MANUAL FOR PROPER ASSEMBLY AND ADJUSTMENT OF HITCH.

10075

Part Number: 10075

Location: Left Side of Valve Shroud

# IMPORTANT

## IMPROPER HYDRAULIC HOOK-UP CAN CAUSE SERIOUS DAMAGE TO VALVE

- REFER TO ATTACHING KIT OR PTO PUMP KIT MANUAL FOR PROPER HYDRAULIC HOOK-UP.
- NEVER PRESSURIZE RETURN PORT OF VALVE OR RESTRICT RETURN HOSE.
- ALWAYS MOVE TRACTOR 3-POINT HITCH CONTROL TO FULLY LOWERED POSITION WHILE BACKHOE IS MOUNTED TO TRACTOR.

Part Number: 10052

Location: Left Side of Valve Mount Plate

# WARNING

TO PREVENT BODILY INJURY: DO NOT OPERATE THIS BACKHOE UNLESS IT IS RIGIDLY ATTACHED TO THE TRACTOR USING THE APPROPRIATE FACTORY-PROVIDED MOUNTING KIT. DO NOT MOUNT BACKHOE ON A 3-POINT "QUICK ATTACHING COUPLER."

10076

Part Number: 10076

Location: Top of Seat Bracket

## AVOID ACCIDENTS

BUILT-IN SAFETY FEATURES CAN BE EFFECTIVE ONLY IF PROPERLY MAINTAINED AND UTILIZED

# CAUTION

1. READ OPERATOR'S MANUAL BEFORE USING BACKHOE.
2. OPERATE BACKHOE CONTROLS ONLY FROM NORMAL BACKHOE OPERATOR'S SEAT POSITION.
3. OPERATE ONLY WITH STABILIZERS DOWN AND ON FIRM FOOTING. AVOID DIGGING IN AREA OF STABILIZER PADS. STAY CLEAR OF STEEP AREAS OR EXCAVATION BANKS THAT COULD GIVE WAY.
4. CHECK THE OPERATING AREA TO BE DUG FOR ANY POSSIBLE OVERHEAD OR UNDERGROUND LINES SUCH AS ELECTRIC, GAS, OIL, WATER, ETC., AND EXTREME CAUTION MUST BE EXERCISED IN THESE AREAS WHERE PRESENT. CONSULT LOCAL UTILITIES BEFORE DIGGING.
5. KEEP BYSTANDERS AWAY FROM MAXIMUM SWING REACH AREA AND STABILIZERS.

10088

Part Number: 10088

Location: Left Side of Control Shroud

# CAUTION

6. KEEP ALL GUARDS IN PLACE.
7. INSPECT BACKHOE DAILY FOR LOOSENED, BENT, OR BROKEN PARTS.
8. ENGAGE SAFETY LOCKS BEFORE TRANSPORTING OR SERVICING BACKHOE.
9. BE SURE TRACTOR IS WEIGHTED TO PROVIDE AT LEAST 20% OF TOTAL WEIGHT ON FRONT WHEELS WITH BACKHOE IN TRANSPORT POSITION.
10. DO NOT USE WITH TRACTOR HYDRAULIC SYSTEMS THAT EXCEED 8 GPM FLOW RATE OR 2500 PSI OPERATING PRESSURE.
11. FOR 3-POINT RIGID MOUNT BACKHOES ONLY: MOUNT ONLY TO TRACTORS FROM 20 TO 45 PTO HP WITH CAT I OR II HITCH. 1050 LB. LIFT FORCE REQUIRED AT 24 IN. BEHIND LIFT POINT.

10089

Part Number: 10089

Location: Right Side of Control Shroud

# BASIC ASSEMBLY INSTRUCTIONS

## General:

The backhoe has been partially disassembled and strapped to a skid for shipping purposes. Initial installation on the tractor will require a hoist or other device capable of safely lifting the entire backhoe from the skid. Once the initial installation is complete the backhoe can serve as its own erecting hoist, by lowering stabilizers and bucket to the ground, and additional lifting devices will not be required for normal removal and reattaching.

## Assembly Procedure:

*NOTE - The terms RIGHT and LEFT for all backhoe components are determined from the position of the operator when seated in the operating position on the backhoe.*

**⚠ CAUTION - DO NOT** cut any strapping that fastens the backhoe mainframe to the crate base or fastens the dipperstick to the boom at this time.

1. Remove the stabilizer assembly, bag of parts, and any other miscellaneous items which have been fastened to the skid and conveniently arrange these items.
2. Remove corrugated packaging from R.H. stabilizer cylinder.

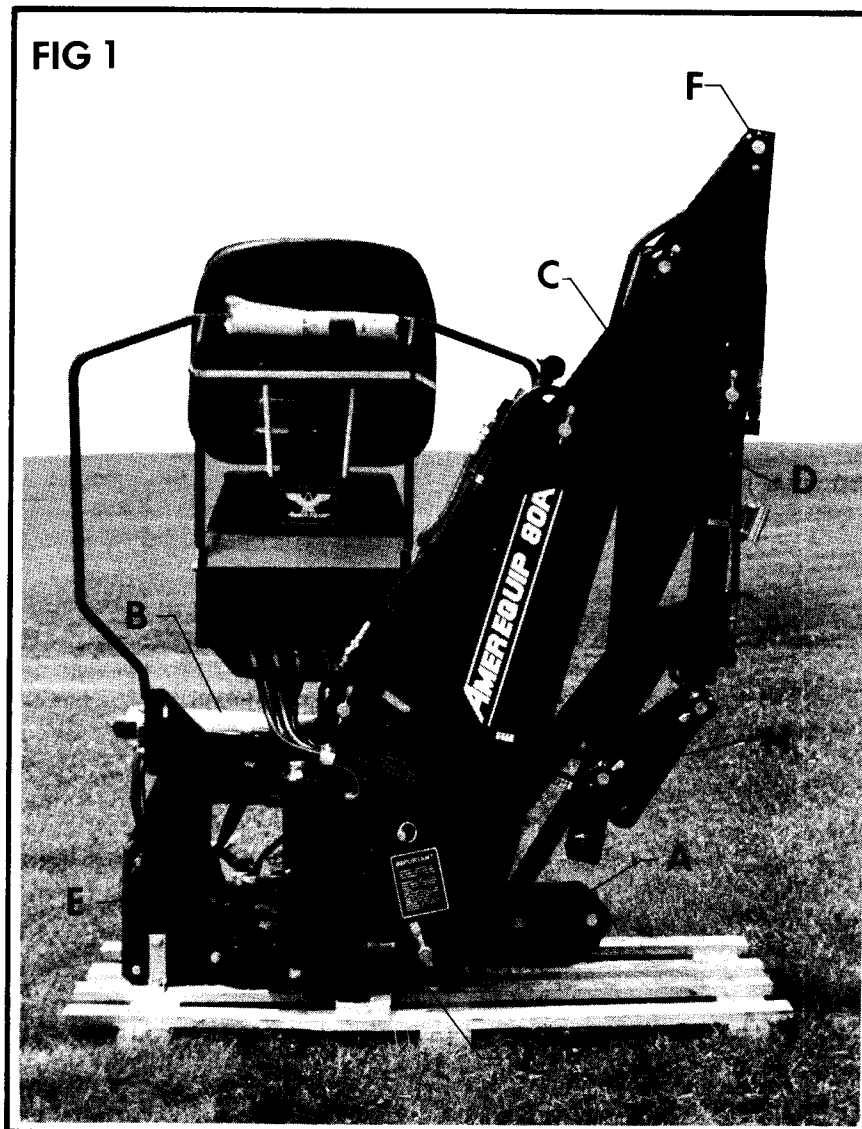

**IMPORTANT** - Tighten all hardware to torque requirements specified in Torque Chart, page 31, of this manual.

3. Attach RH stabilizer (A) to mainframe using pin and hardware assembled to mainframe. See Fig 1.

4. Attach RH stabilizer cylinder (B) to stabilizer and mainframe using pins and hardware provided. Be sure cylinder and hoses are oriented in the same manner as the LH stabilizer. See Fig 1 and Fig 3.

5. Support boom (C) and dipperstick (D) with hoist.

**⚠ CAUTION** - Be sure hoist being used is suitable, has sufficient capacity, and is in the proper position. Do not allow anyone under a backhoe member that is supported by the hoist.

6. Remove strapping from boom (C) and dipperstick (D) only. See Fig 1.

7. Remove boom transport lock pin.

8. Store lock pin in top of valve cover when not in use.

9. Cut wire securing RH swing cylinder to mainframe. Manually extend RH swing cylinder (E) fully. Then move RH swing linkage to the approximate position shown in Fig 2.

10. Attach base end to mainframe with pins provided.

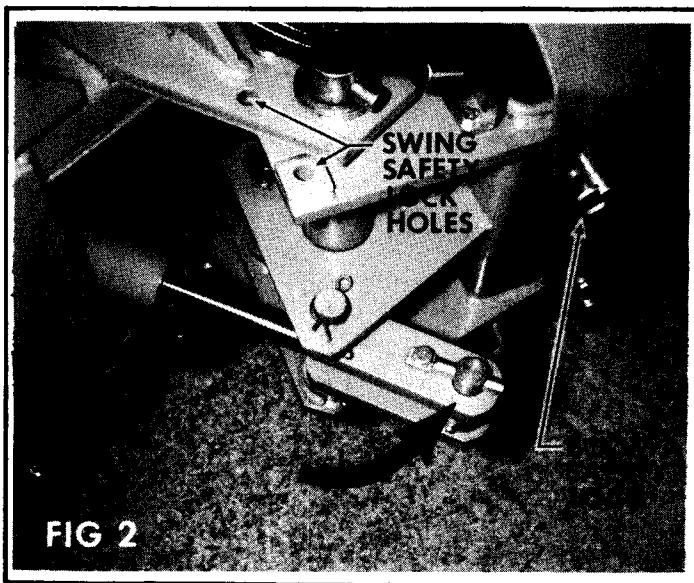

11. Carefully swing boom away from mainframe until centered, using hoist to prevent the backhoe from tipping. Move swing control lever to "SWING RIGHT" position and manually force LH swing links against swing frame while moving boom to center position. Place swing transport pin in position, to keep boom from swinging further. See Fig 2.

12. Lower boom and dipperstick to 12" above ground using hoist and place blocking securely under end of boom. Move control handle to "BOOM DOWN" position as required to aid movement, and manually extend dipperstick. Attach dipperstick cylinder to dipperstick at point (F) using pin and hardware provided. See Fig 1 and Fig 3. Reposition hoist by hooking onto mainframe, near main pivot pin and swing safety lock.

13. Attach bucket (G) to dipperstick using a 1" diameter x 7-3/8 inch pin, two 5/16 NF x 7/8 bolts, two pin retainers, locknuts, and washers as needed to take up gap under pin retainers. See Fig 3.

14. Attach bucket link (H) to bucket using same hardware as listed for #13. See Fig 3.

15. Remove remaining strapping and use hoist to raise mainframe. Remove crate base using caution to prevent tipping of backhoe. Raise backhoe mainframe approximately 10 inches and block securely.

16. Attach LH bumper (J) to mainframe using two 5/16 NF x 1-1/4 bolts, washers, and lockwashers. See Fig 1.

17. Follow the Attaching Kit Assembly Instructions to mount the backhoe to the tractor. Check the installation carefully making sure that all members are correctly installed and securely fastened.

18. Assemble 1-9/16 ID x 18" hose sleeve on hose which attaches to backhoe valve "in" port. Position hose sleeve to cover adapter union and secure with plastic tie.

**⚠ CAUTION** - Hose sleeve is installed to help protect the backhoe operator from escaping fluid under pressure. If it becomes damaged or lost, replace hose sleeve and plastic tie immediately, see Fig 18.

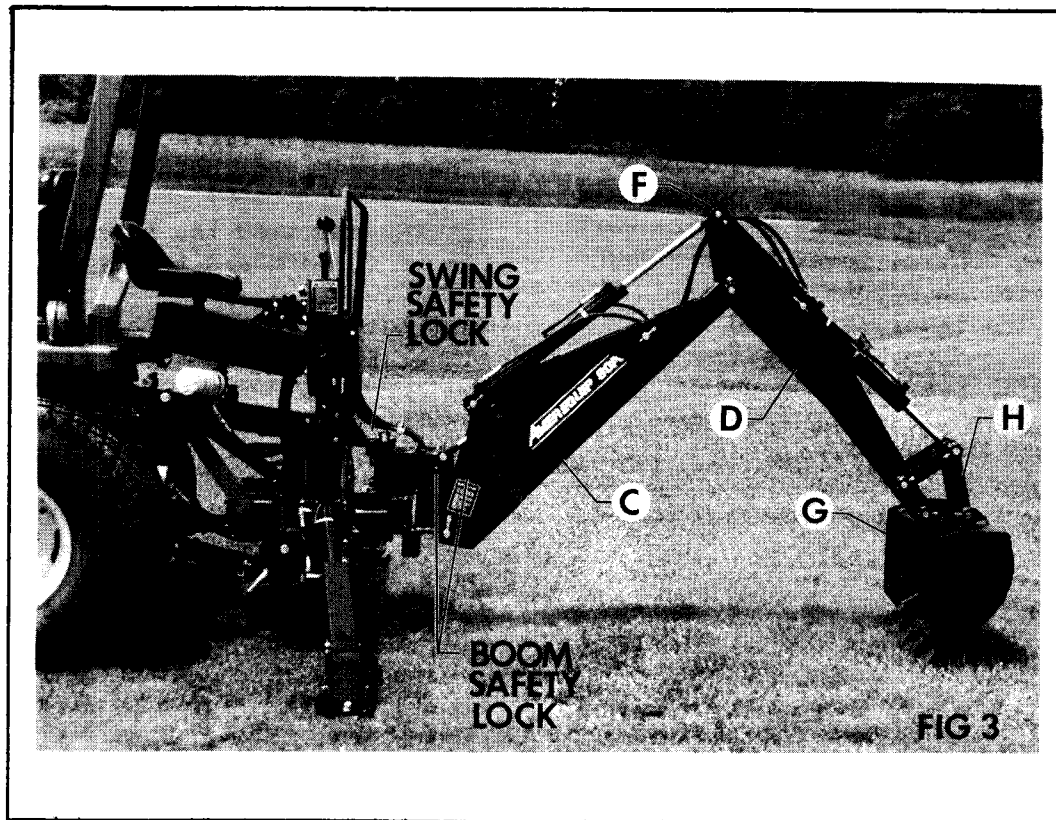

## GENERAL OPERATION



**CAUTION** - To avoid possible injury, observe the following safety rules **BEFORE OPERATING** the backhoe:

1. **BE SURE** area is clear of underground utilities or other hazards.
2. **POSITION** a barricade around work area.
3. **PROVIDE** adequate front end weight to counter-balance backhoe at all times. 20% of the total tractor, loader, backhoe weight must be on the tractor front axle.
4. **KEEP** bystanders a safe distance away.

### Directions:

The terms right, left, front, and back shall be determined from the position of the operator when seated in the operating position on the backhoe.

### Engine Speed:

The speed at which the backhoe operates is partially dependent on engine RPM. Use a moderate engine speed to start and increase it as your experience permits. Refer to "SPECIFICATIONS" for hydraulic flow volume requirements. When powering from tractor systems with higher output,

reduce engine RPM to obtain acceptable backhoe operating speed.

### Controls:

The backhoe has two major control levers plus the stabilizer control levers. These controls are located on the control panel directly ahead of the operator, see Fig 4. Following is a list of the controls, with the function of each, reading from left to right.

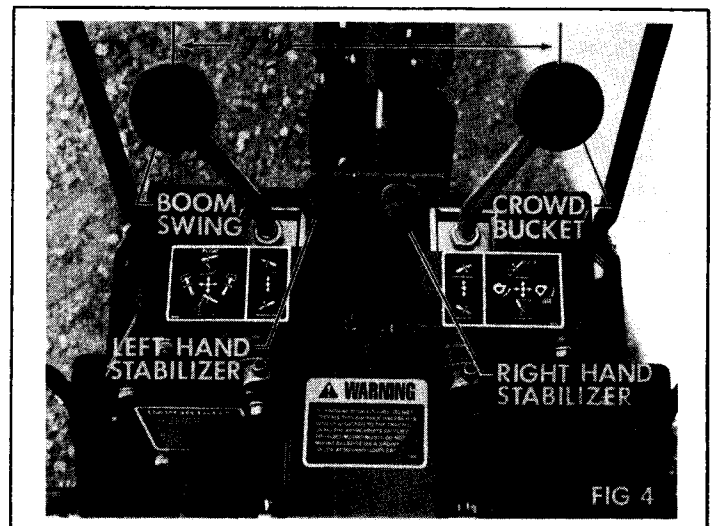



## General Operations - continued

### 1. Boom/Swing:

Push lever forward, the boom moves down, away from the operator. Pull lever back, the boom moves up, toward the operator.

The Boom/Swing Control Lever has an added "float" function. A detent or stop should be felt when the lever is pushed forward to move the boom down. Pushing the lever forward more will overcome the detent and cause the boom to float or move down or up freely depending on the forces acting on it. When the lever is released it should return to the center, neutral position.

Move lever to left, the backhoe swings to the left. Move lever to right, the backhoe swings to the right.

By moving the lever to one of the intermediate positions, the boom can be swung left or right at the same time it is being raised or lowered, performing the two operations simultaneously.

**SWING LEFT AND LOWER** the boom by moving the control lever forward and to the left.

**SWING LEFT AND RAISE** the boom by moving the control lever back and to the left.

**SWING RIGHT AND LOWER** the boom by moving the lever forward and to the right.

**SWING RIGHT AND RAISE** the boom by moving the lever back and to the right.

### 2. Left Hand Stabilizer:

Push lever forward, the LH stabilizer lowers. Pull lever back, the LH stabilizer raises.

### 3. Right Hand Stabilizer:

Push lever forward, the RH stabilizer lowers. Pull lever back, the RH stabilizer raises.

### 4. Crowd/Bucket:

Push lever forward, the dipperstick moves out, away from the operator. Pull lever back, the dipperstick moves in, toward the operator.

Move lever to left, the bucket curls in. Move lever to right, the bucket extends out.

By moving the lever to one of the intermediate positions, the dipperstick can be extended or retracted at the same time the bucket is being loaded or dumped.

**EXTEND AND LOAD** the bucket by moving the lever forward and to the left.

**RETRACT AND LOAD** the bucket by moving the lever back and to the left.

**EXTEND AND DUMP** the bucket by moving the lever forward and to the right.

**RETRACT AND DUMP** the bucket by moving the lever back and to the right.

The two operations of the boom lever, combined with the two operations performed by the bucket and dipperstick control lever provide four simultaneous operations from the two levers, keeping cycle time at a minimum.

In general, the direction of movement of a control lever corresponds to the movement of the operating member.

## Operating The Backhoe:



*CAUTION - To avoid possible injury, observe the following safety rules WHEN OPERATING the backhoe:*

1. **DISENGAGE** safety locks as shown in Fig 1, before attempting to operate the backhoe. Store lockpins in holes provided in top of valve shroud.
2. **OPERATE** from the backhoe operator's seat only.
3. **LOWER** the stabilizers until the rear of the tractor is totally supported by them. **NOTE:** rear tires should not come up off of the ground, see diagram on page 10.
4. **DO NOT** dig near the stabilizers.
5. **DO NOT** touch overhead wires with any part of the backhoe.
6. **DO NOT** attempt to raise the tractor off the ground or move the tractor forward or backward using the backhoe dipperstick or bucket.
7. **DO NOT** lose stability by swinging the bucket downhill when positioned on a slope.

General Operations - continued

8. DO NOT lower the backhoe boom using the "float" function. It will free-fall, and could result in injury to bystanders or damage to the backhoe.

It is not difficult to become an efficient operator. Control lever operating decals are located in front of the control levers. Study these decals; they will assist you in becoming familiar with the controls.

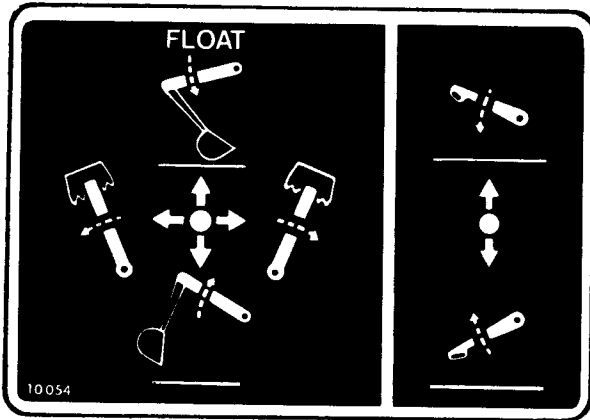

Part Number: 10054

Location: Top of Control Shroud, left side

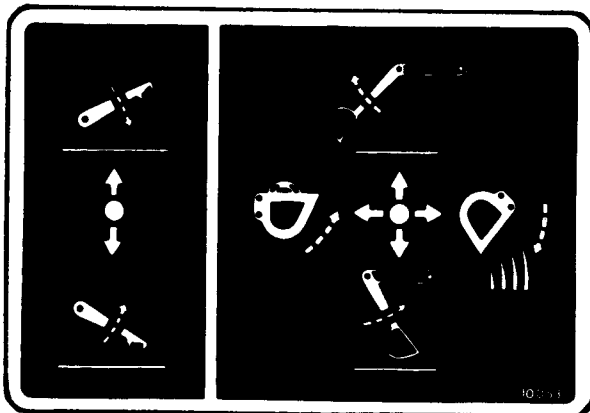

Part Number: 10053

Location: Top of Control Shroud, right side

Smooth, light handling of the controls will result in the most efficient backhoe operation.

Operate the backhoe control levers to become familiar with their speed and movements. The engine speed and the size of the hydraulic system will determine the speed of cylinder operation. When powering from tractor systems with higher output than required, reduce engine RPM to obtain acceptable backhoe operating speed.

Swing the boom several times to practice controlling the speed of swing. Do not operate the swing more than 45 degrees each way for the first few times, then gradually increase the arc.

*IMPORTANT* - To avoid damage to the backhoe, do not slam swing unit into the rubber bumper pads.

The boom "float" function may be used during digging to eliminate down pressure when cleaning the bottom of a trench. The primary purpose of the boom "float" function is to protect the operator from serious injury in the event that the backhoe or tractor hitch would fail.

Best results are obtained by digging near the center of the swing arc so material can be dumped on either side.

As the operator becomes more familiar with the operation of the backhoe, it will be common practice to operate two controls at one time. For example; with the bucket extended and the dipperstick extended, the lift control and crowd control can be operated together to bring the bucket toward the operator with down pressure on it. As the dipperstick approaches the operator, the crowd and bucket controls can be operated to close the bucket and trap the material. At the end of the stroke, the lift and crowd controls are operated to move the load up and away from the operator to save time in clearing the excavation.

This dual operation of controls will speed and simplify the digging operation. Normally the two or more movements will not be equal or even simultaneous but as pressure within the cylinders change, and the resistance on an operating member of the hoe lessens, it will begin to move. It is balancing the force of one member against the other.

*NOTE* - Actuating the bucket is the key to powerful digging. Operating the crowd and bucket controls simultaneously will insure a full bucket and prevent waste motion and time.

### Transporting The Backhoe:

**⚠ CAUTION** - To avoid possible injury, observe the following safety rules WHEN TRANSPORTING the backhoe:

1. ALWAYS engage safety locks as shown in Fig 3, when transporting backhoe.
2. TRAVEL SLOWLY over rough terrain, on hillsides, and around curves to prevent tipping.
3. DO NOT drive the tractor near the edge of a ditch or excavation.
4. USE accessory lights and SMV emblem when traveling on highways.

Before leaving backhoe operator's seat, position the backhoe for transport by raising boom, crowding dipperstick in, curling bucket in, swinging to center, and raising the stabilizers.

When transporting for long distances, periodically examine the backhoe and raise stabilizers and bucket back up to full transport height. It is normal for the hoe to slowly settle while being transported.

*IMPORTANT - To prevent serious damage to the tractor, read and follow the instructions on the following decal:*

## IMPORTANT

**IMPROPER TRANSPORTING METHODS CAN CAUSE SERIOUS DAMAGE TO TRACTOR.**

- ENGAGE BOTH SAFETY LOCKS WHEN TRANSPORTING BACKHOE.
- TRAVEL SLOWLY OVER ROUGH TERRAIN.
- WHEN TRANSPORTING ON TRUCK OR TRAILER, LOWER BACKHOE BOOM SO BUCKET RESTS FIRMLY ON BED. APPLY RESTRAINTS TO TRACTOR, NOT TO BACKHOE OR BACKHOE ATTACHING KIT.

10099

Part Number: 10099  
Location: Right Side of Boom

### PLACING THE STABILIZERS:

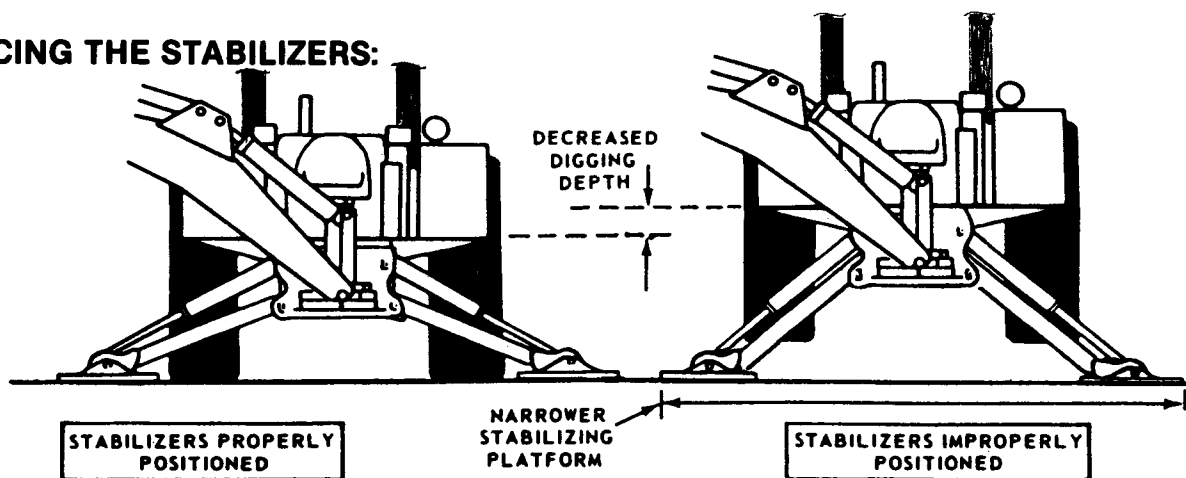

Set the stabilizers to remove weight from the rear wheels. The wheels are to remain touching the ground as this provides for the widest stabilizer stance and the lowest center of gravity. Raising the wheels off the ground will not only reduce stability and digging depth, but will impair performance and impose unnecessary stress on the unit.

## General Operations - continued

### FILLING THE BUCKET

Control the bucket attitude throughout the digging cycle to keep teeth at the proper angle for best penetration. This will minimize dragging and scraping the bucket through the ground.

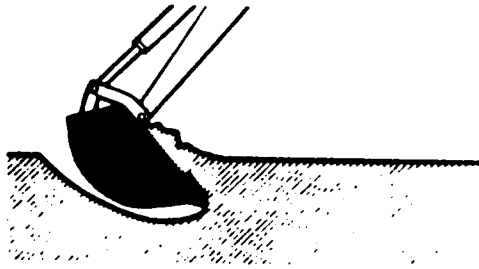

When digging in hard-packed soil, bucket penetration can be increased by applying down pressure with the boom while crowding in and curling the bucket. If the crowd action "stalls," it may be necessary to apply lift occasionally during the digging cycle to correct the bucket depth.

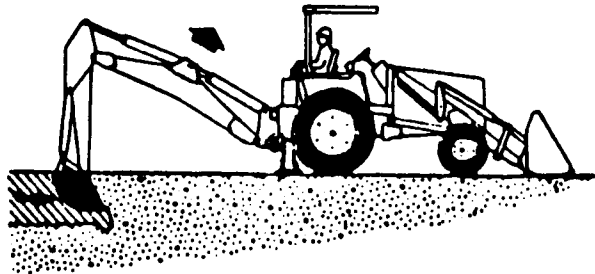

To obtain a cleaner trench and avoid the buildup of material directly in front of the backhoe, crowd out and completely curl the bucket while starting to lift it from the excavation. In this way, excess material will fall back into the excavation.

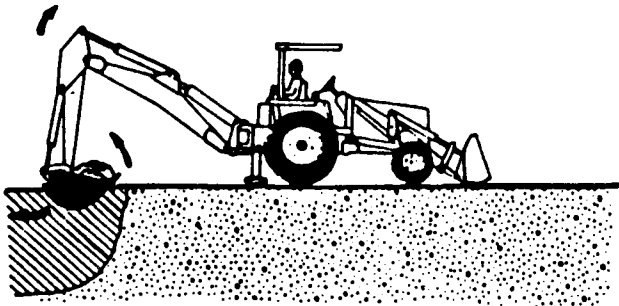

### DUMPING THE BUCKET

To dump the bucket at the end of the digging cycle, lift the bucket clear of the trench while crowding it out and swinging it to the spoil pile.

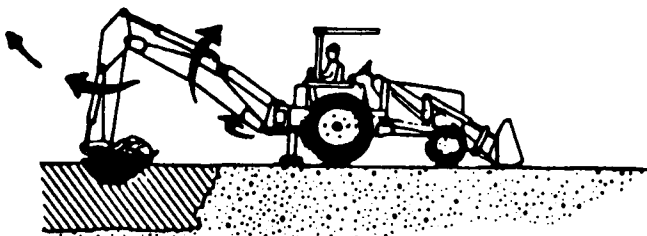

As the pile is approached, dump the bucket. When the bucket is empty, the dipstick and bucket are in position to resume digging upon return to the trench.

**IMPORTANT** — Avoid constant jarring or hammering-type contact between the spoil pile and the loaded bucket as this may cause premature wear to the backhoe pins and bushings.

### TRENCHING BETWEEN A BUILDING & OPEN EXCAVATIONS

Start the trench at the building. Trench out halfway to the excavation. Then, start trenching from the excavation to the first trench. Dig toward the first trench until there is just enough room to move the unit out from between the two trenches.

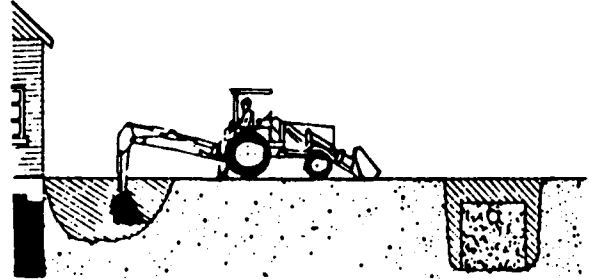

Position the unit so the backhoe swing post is over the centerline of the trench connection. Dig with the backhoe at extreme swing positions, and in as close to the stabilizers as possible. Pile the spoil on the opposite side of the trenches.

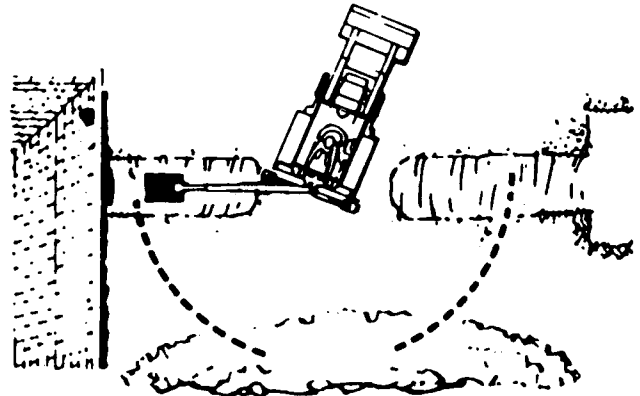

Position the unit forward with the lift and crowd levers so the two trenches can be connected. Pile the spoil on the opposite side of the trench.

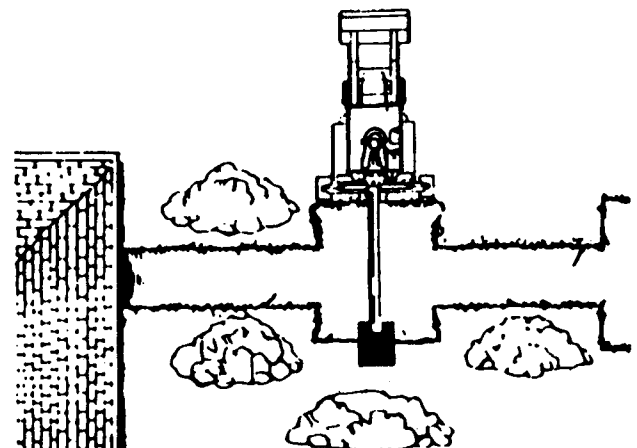

General Operations - continued

### SIDE SLOPE EXCAVATING OR TRENCHING

Dig with the backhoe uphill whenever possible.

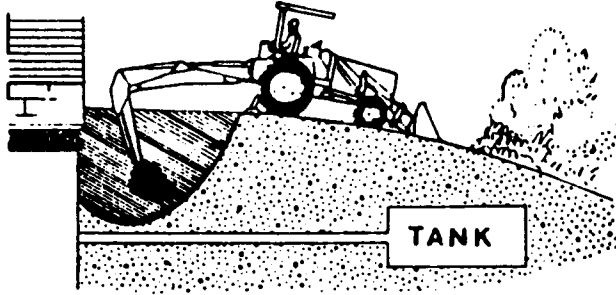

Level the backhoe on slopes with the stabilizers to dig plumb trenches, or use the backhoe or loader to cut a level slot for the uphill wheel and stabilizer. Pile the spoil from the slot on the low side.

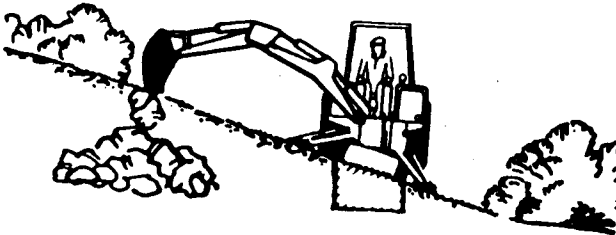

When on the side of a steep slope, cut a level surface along the uphill side of the trench with the loader.

Pile the spoil of the cut downhill. When digging, pile the spoil of the trench uphill.

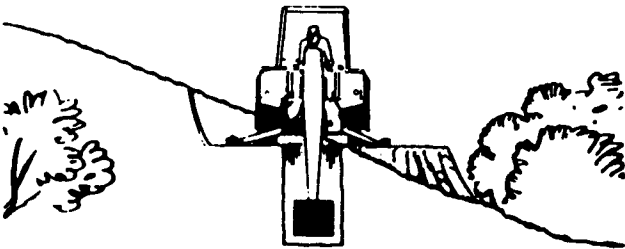

Dig field trenches progressively. As soon as one trench is completed, have the workmen lay the tile. Start the next trench, using the spoil to fill the previous trench.



### MISCELLANEOUS

When finishing straight walls or bellholes in sandy soil, use a platform under the rear tires and the stabilizers. The platform distributes the load over a larger area and lessens the possibility of a cave-in. The platform also tends to keep the unit from creeping rearward if hard digging is encountered.

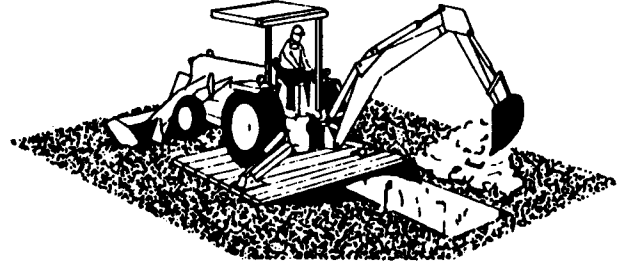

### FINISHING STRAIGHT WALLS

Finish the far wall by crowding out while forcing the bucket down with the boom. Actuate the bucket (curl out) to keep the bottom of the bucket vertical.

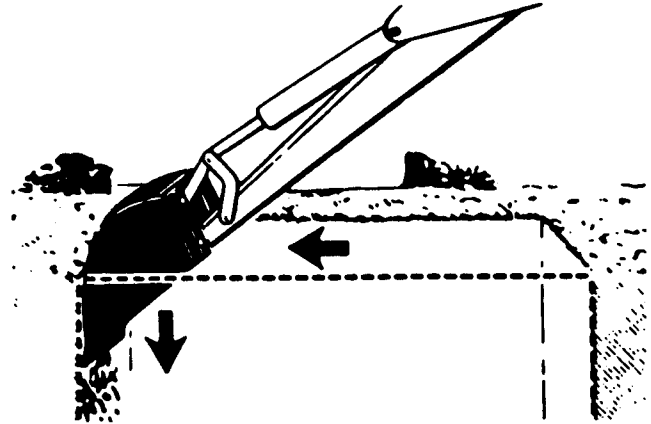

To finish the rear wall, lift up and crowd in. Keep the edges of the bucket horizontal.

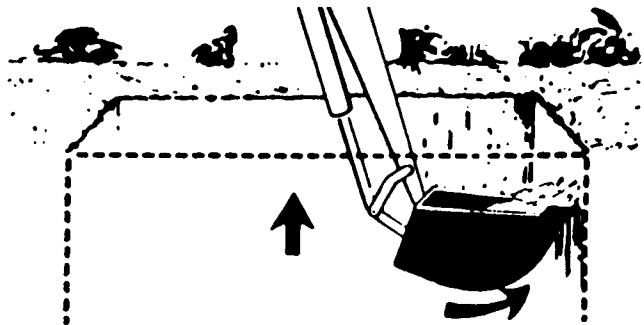

### BACKFILLING

Backfill by lifting the bucket over the spoil pile and then crowding in. Pull both the crowd and lift levers for smooth, even backfilling.

**IMPORTANT** — Do not backfill by using the swing circuit and dragging the bucket sideways. Doing so can cause damage to the dipstick, boom, swing cylinders or mainframe.

## SERVICE

**CAUTION** - To avoid possible injury, observe the following safety rules WHEN SERVICING the backhoe:

1. ENGAGE safety locks as shown in Fig 3, before servicing the backhoe.
2. DO NOT oil, grease, or adjust the backhoe while it is in motion.
3. DO NOT change any backhoe relief valve settings. They are factory set for best backhoe performance and safety.

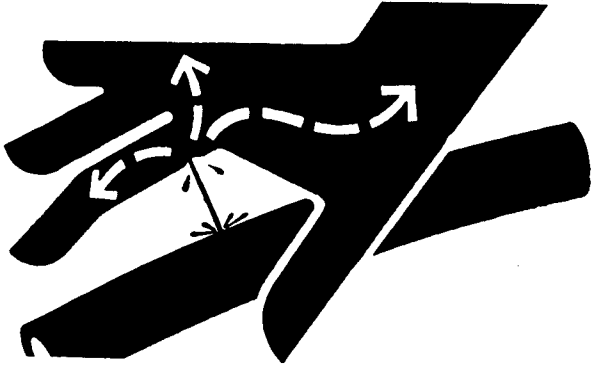

4. ESCAPING FLUID under pressure can have sufficient force to penetrate the skin and cause serious injury. Be sure to relieve all pressure before disconnecting lines. Be sure all connections are tight and that lines, pipes, and hoses are not damaged before applying pressure to the system.
5. FLUID ESCAPING from a very small hole can be almost invisible. Use a piece of cardboard or wood - not your hands - to search for suspected leaks.
6. SEE A DOCTOR AT ONCE if injured by escaping fluid. Serious infection or gangrene can develop if proper medical treatment is not administered immediately.
7. PROTECT YOUR EYES - WEAR SAFETY GLASSES. Guard against injury when driving connecting pins or performing any repair in which particles can chip from work piece or striking tool.

### Beginning Of Season:

Remove all protective covering.

Check hydraulic hoses for deterioration and, if necessary, replace.

Lubricate all grease fittings and oil handle linkage.

Check hydraulic system for loss of fluid and, if necessary, fill to proper level.

Tighten all loose bolts, nuts, and set-screws.

Inspect bucket teeth and, if necessary, sharpen or replace them.

Operate the backhoe slowly for a short time before placing the unit under full load.

### Bleeding Backhoe Hydraulic System:

If the hydraulic hoses have been disconnected from the backhoe or tractor, all trapped air must be removed after the hoses are connected. Start tractor engine and operate backhoe through all movements fully, several times, to purge the system of air.

### Hydraulic System Hoses:

Oil leaks in the pressure side of the system can be located by carefully inspecting the external area of the hoses and fittings.

Check the return side of the system for leaks by examining the oil in the reservoir. If air is being drawn into the system, the oil will contain air bubbles and appear to foam.

When tightening connections, always use two wrenches.

*IMPORTANT - Do not over-tighten fittings. Make them just tight enough to eliminate leaks.*

NEVER use teflon tape on pipe thread fittings. Always use a paste type sealer.

Hoses on any backhoe are very severely worked and will fail in time. Examine them regularly and replace any that show signs of failure. Pay careful attention to the routing of hoses so they can move fully and freely, without kinking, and can not be pinched or cut by any part of the backhoe.

### Hydraulic System Reservoir:

On PTO pump self-contained systems, maintain the reservoir fluid level at 1 inch below the tank top when the bucket is extended to full reach, bucket rolled back for loading and resting on the ground, and stabilizers fully raised. Do not over-fill, fluid may be forced out of the breather filler cap.

Service - continued

Fill with:

SAE 10W40 engine oil with API "SD" classification in northern climates.

SAE 40W engine oil with API "SD" classification in southern climates.

Change oil and oil filter every 200 hours or more often if necessary.

If the tractor system supplies the hydraulic power, service according to the tractor instruction manual.

### Bucket Tooth Points:

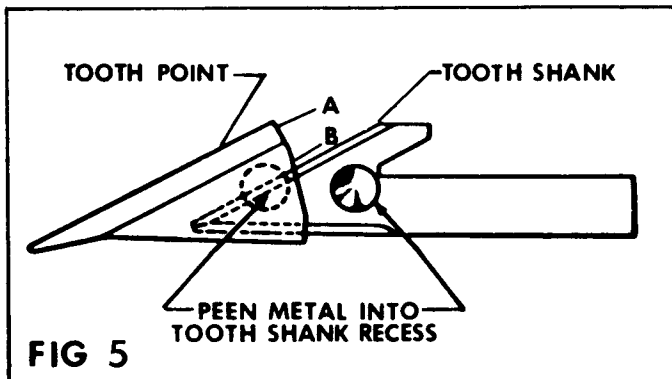

The bucket tooth points are self-sharpening and will require little attention; however, these points on the bucket shanks can be replaced when they become badly worn or broken.

A tooth point can be removed from the welded tooth shank by hammering at "A" on the tooth point or by driving a chisel at "B", just between the tooth point box section and the tooth shank. Install the new point and anchor it to the shank by peening at the location shown.

If a tooth shank breaks off, becoming lost or damaged so that it can not hold a tooth point, a new shank should be welded to the bucket in its place.

### Tightening Nuts And Bolts:

Periodically, check to be sure all bolts and nuts are tight, see Torque Chart, page 31, of this manual.

Check all pivot pins for cotter pins, washers, and retainers; if missing - replace.

### LUBRICATION:

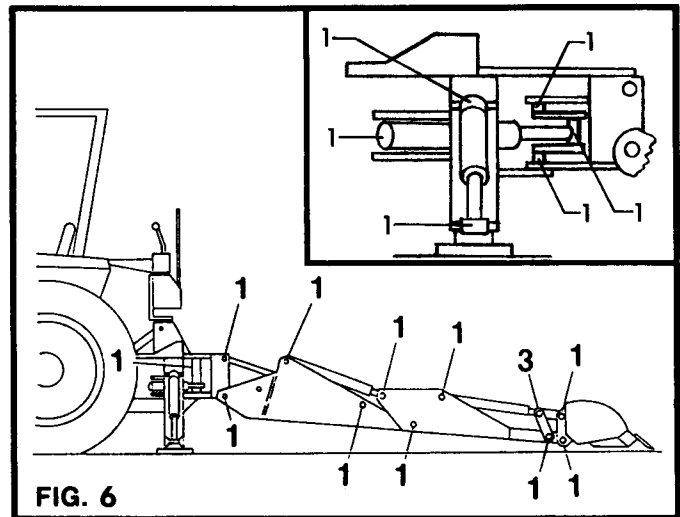

Economical and efficient operation of any machine is dependent upon regular and proper lubrication of all moving parts with a quality lubricant.

All parts provided with grease fittings should be lubricated with a good quality chassis lube type grease. If any grease fittings are missing, replace them immediately. Clean all fittings thoroughly before using grease gun.

Lubricate all grease fittings at least twice daily, once at the beginning of operation and again approximately half-way through the work day.

Lower stabilizers to the ground, extend dipperstick and bucket, and lower boom so bucket rests on ground, as shown in Fig 6, before greasing.

See Fig 6, for the location of all grease fittings. In addition to those fittings shown in large illustration, the following must also be greased twice daily:

- A. Stabilizer cylinder pivot pins (2 each cylinder). See Fig 6 Inset.
- B. Swing cylinder pivot pins (2 each cylinder). See Fig 6 Inset.
- C. Swing linkage (2 each side). See Fig 6 Inset.

The following locations should be oiled with SAE 30 oil:

- A. Control valve handle linkage.
- B. Seat bracket pivot.

**IMPORTANT** - Avoid excessive greasing. Dirt collects on exposed grease and increases wear greatly. After greasing wipe off excessive grease from fittings.

# REMOVAL FROM TRACTOR-STORAGE

The backhoe is self-assisting during the installation and removal procedures. For removal and storage follow these steps:

1. Install the swing safety lock pin as shown in Fig 3, and raise the backhoe operator's seat until it locks in the raised position.
2. Put the stabilizers down and lift the hoe slightly.
3. Stretch out the boom, dipper arm, and bucket, as shown in Fig 7. Lower the bucket to the ground so that it rests there solidly.
4. Place suitable blocking under the backhoe frame to support it adequately, as shown in Fig 7.
5. Detach the backhoe from the tractor mechanically only, not hydraulically at this point, and move the tractor a few inches away from the backhoe.

*NOTE - To facilitate this procedure, the backhoe can still be hydraulically moved, raised or lowered, to release the connection points of the carrying forces.*

6. Gently lower the backhoe onto the blocking as shown in Fig 7. Leave the stabilizers outstretched and firmly in contact with the ground for added stability.

7. The hydraulic system can now be de-actuated.

**⚠ CAUTION** - Make sure tractor PTO is disengaged, and engine shut off before disconnecting pump or hydraulic lines.

- a. On PTO pump self-contained systems, the pump should be removed from the PTO shaft. The hydraulic system should always remain complete. No hoses or oil lines should be disconnected during correct removal and storage procedure.
- b. On systems that tap into the tractor for hydraulic power, these lines can be disconnected now.

*IMPORTANT - Be sure to mark the lines to prevent mix up, during hook-up, when the hoe is again attached to the tractor.*

Be sure to cap the ends of the lines to keep clean while in storage.

8. Now slowly drive the tractor forward and away from the backhoe. Be careful that all parts clear each other during separation.

9. Refer to the installation instructions for the attaching kit, this will help with the removal and reattaching.

10. For long term storage, coat exposed lift, swing, and stabilizer cylinder rods with grease.

11. Lubricate all grease fittings and oil stabilizer pivot pins, and complete handle linkage.

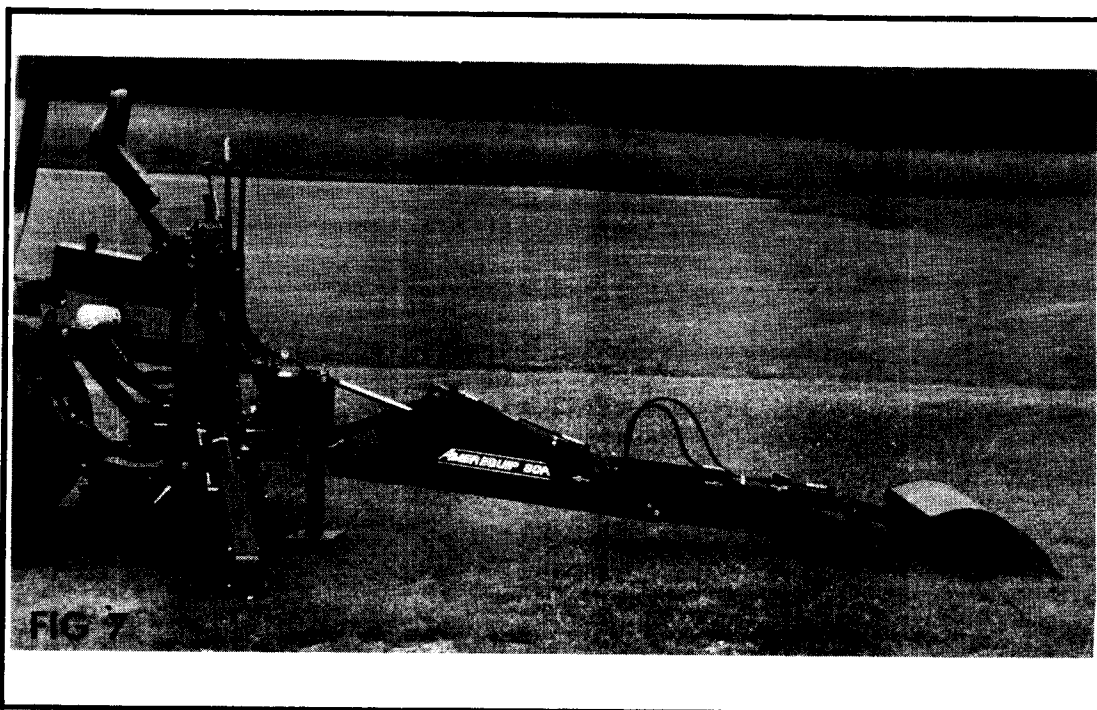



# HYDRAULIC TROUBLE SHOOTING

The trouble shooting material presented in this section is offered as a guide to diagnosing probable causes and remedies for general operational problems. Match your problem with the typical problem examples given, and note the numbers given in the possible cause column. These numbers correspond with the possible cause and correction paragraphs that follow.

**NOTE** — When using the following chart if it is decided that overhaul of components or pressure adjustments are necessary, to correct malfunctioning, it is recommended that your dealer make these repairs. He is equipped to do this work.



**WARNING:** Escaping hydraulic/diesel fluid under pressure can penetrate the skin causing serious injury.

**DO NOT** use your hand to check for leaks. Use a piece of cardboard or paper to search for leaks.

Stop engine and relieve pressure before connecting or disconnecting lines.

Tighten all connections before starting engine or pressurizing lines.

If any fluid is injected onto the skin, obtain medical attention immediately or gangrene may result.

PROBLEM	POSSIBLE CAUSE
A. Machine fails to operate when started initially.....	1, 2, 5, 7, 16, 24
B. Machine loses power after operating satisfactorily initially.....	1, 8, 10, 14, 16, 24
C. Loss of power in lift or crowd cylinder, but other cylinders function properly.....	23, 25, 30
D. Loss of power in any one cylinder including lift and crowd.....	8, 9, 10, 11, 12, 13, 23, 25, 26
E. Loss of power or loss of cushioning action in swing cylinders, but other cylinders function properly.....	8, 9, 10, 11, 12, 13, 23, 24, 26, 27
F. Maximum swing action can not be obtained.....	12, 15
G. Slow operation of machine (lack of power) all cylinders.....	1, 4, 6, 14, 16, 24
H. Spongy or jerking action of cylinders and/or noisy operation.....	1, 3, 4, 5
I. Lift, crowd, or bucket cylinders drop under load when control spools are shifted from neutral.....	28, 30
J. Load drops or settles.....	8, 10, 13, 26, 28
K. Leaky cylinders.....	10, 11, 12, 13
L. Leaky valve.....	8, 16, 17, 29
M. Sticky valve spool.....	17, 20, 21, 22
N. Unable to push valve spool in.....	17, 18, 20, 21, 22
O. Spring centered spools do not return to neutral.....	17, 18, 19, 20, 21, 22

Hydraulic Trouble Shooting - continued

POSSIBLE CAUSE:

AND CORRECTION -

1. Low oil level in reservoir.....fill reservoir to proper level.
2. No oil supply to machine.....oil is not being diverted from the prime mover hydraulic system. Be sure that the proper controls are actuated on the prime mover.
3. Air in system.....bleed all circuits of air by operating machine at maximum oil flow and through full movements.
4. Oil viscosity too heavy, or oil is....use recommended hydraulic fluid. Run not at operating temperature. machine until oil reaches operating temperature.
5. Pump not running.....check pump drive to be sure it is engaged.
6. Insufficient pumping.....advance engine throttle.
7. Improper hose connection.....*IMPORTANT - Be sure inlet and return hoses are hooked up correctly. Improper hook-up will result in damage to the backhoe valve.*
8. Loose oil line connections, leaks in....tighten all hose connections and replace lines, or broken lines. any damaged O-rings at leaking O-ring fittings. Check and replace any damaged hoses and lines.
9. Restrictions in oil lines.....check and replace any damaged hoses and lines. Check for pinched hoses.
10. Oil is bypassing cylinder piston,....replace or rebuild the cylinder; replace scored piston, worn piston packing, damaged parts. or defective piston assembly.
11. Scored piston rods and worn rod....replace or rebuild the cylinder; replace guides in cylinder. damaged parts.
12. Bent piston rod in cylinder.....replace or rebuild the cylinder; replace damaged parts.
13. Worn or damaged rod seals on cylin-....repack cylinder. Rebuild cylinder, re-der; external leaks. placing damaged parts as necessary.
14. Diverter valve on prime mover leak-....diverter valve may need rebuilding or ing externally or bypassing oil in- replacing. ternally through valve to reservoir.
15. Something jamming the swing linkage.....remove interference.
16. Excessive back pressure.....relieve condition. May be restriction from outlet to reservoir.

Hydraulic Trouble Shooting - continued

POSSIBLE CAUSE:	AND CORRECTION -
17. Paint on valve spool, sticking valve..... spool, or scored valve spool.	clean valve spool. Binding is usually caused from an over tightened plug, mounting bolt, fitting in valve body, or tie rod bolt. If a plug or fitting in valve body is leaking do not over tighten in an effort to stop leak. This will distort body casting and cause spools to bind. Instead, the plug or fitting should be removed from valve body and be reconnected, using a new O-ring. Do not apply excessive pressure on mounting bolts. The rods should be torqued to 20 ft-lb. Never force spool, if binding occurs, see item 31 at the end.
18. Oil leakage past spool seal into..... spool cap.	remove cap, if it contains oil, replace spool seal O-rings. Check O-ring retainer to see if it is flat. If it has been "belled" check for restriction from outlet to reservoir of valve which would cause excessive back pressure, see item 31 at the end and Fig 9.
19. Broken return springs.....	replace springs, see item 31 at the end and Fig 9.
20. Bent spool.....	replace with new spool section. See item 31 at the end and Fig 10, 11, and 12.
21. Foreign particles.....	clean system and valve.
22. Misalignment of control handle..... linkage.	check linkage for binding condition.
23. Spool not moved to full stroke.....	check travel, should be 5/16 inch either way or a total of 5/8 inch. See item 31 at the end.
24. Relief valve setting in backhoe con- trol valve too low or defective.	relief pressure will have to be checked and corrections made. Backhoe system pressure is 1950 PSI. Relief valve may need cleaning and overhauling, or entire cartridge must be replaced. See item 31 at the end and Fig 13.
25. Overload relief valve in the control..... valve stuck open or malfunctioning.	clean relief carefully but do not disturb its pressure setting as it can not be field calibrated, or replace cartridge. See item 31 at the end and Fig 10 and 11.
26. Worn control valve.....	replace the control valve.

Hydraulic Trouble Shooting - continued

POSSIBLE CAUSE:

AND CORRECTION -

27. A cross over relief in swing circuit.....clean reliefs carefully but do not disturb their pressure setting as they can not be field calibrated, or replace the entire cross over relief assembly.
28. Check poppet in the control valve.....clean check poppet(s) carefully, being sure that it moves freely with good spring action and seats properly or replace. See item 31 at the end and Fig 10, 11, and 12.
29. Damaged or worn spool seals.....replace spool end seals, see item 31 at the end and Fig 10, 11, and 12.
30. Check ball in anti-cavitation check.....clean anti-cavitation valve carefully, being sure that checks move freely and seat properly, or replace cartridge. See item 31 next, and Fig 10 and 11.
31. Problems involving the control valve proper.....

This valve is a precision device and is not intended for any extensive field adjustment or repair. Field replacement parts are limited to Seal Kits, Cartridges, Valve Sections, and Tie Rods. Replacement of these parts, the opening of check cavities and certain relief valve cavities to examine for trapped dirt, or the resetting of the main relief valve with the use of good pressure gauge, should be referred to qualified service personnel.

Dirt and shreds of packing material are the usual causes of valve malfunction. Be sure that the reservoir oil supply is kept clean and only factory supplied packings are used in cylinder repair. Everything must be clean and free of dirt during the oil line removal and replacement and during any cylinder work.

Pages 20 and 21, Valve Repair - Disassembly, explain the procedure to follow for valve repair. Pages 22 through 28 illustrate various portions of the valve and list the part numbers.

THE INCLUSION OF THIS INFORMATION AND ITS USE DOES NOT IMPLY THAT THE WARRANTY WILL REMAIN EFFECTIVE ON THE VALVE IF IT IS TAMPERED WITH DURING THE WARRANTY PERIOD.

# VALVE REPAIR - DISASSEMBLY

---

## Replace Center Section Assemblies:

*NOTE - For the purpose of these instructions, we will consider the section containing the MAIN RELIEF VALVE as the left side of the valve.*

1. Remove control valve from the backhoe.
2. Thoroughly clean the exterior of the valve before beginning disassembly procedures.
3. Since the valve will be assembled in the same order, each section should be marked numerically so that they can be reassembled in the same sequence.
4. Mount the valve vertically in a vise to facilitate disassembly and assembly.
5. Remove the three tie rod nuts from the right end section, using a thin-wall socket.
6. Valve sections can now be removed by sliding the sections along the tie rods.
7. Thoroughly clean the O-ring counter-bores and the ground surfaces of each section. Place O-ring seals; 10318 (exhaust) and 10317 (pressure) in proper counter-bores. For better sealing it is recommended that all O-rings, used in the counter-bores, are replaced with new parts.
8. Replace the sections on tie rods with the O-ring counter-bores facing the right end of the valve. Be careful replacing the sections so that the section O-rings are not moved from the counter-bores.
9. When all sections are assembled on the tie rods, tighten the tie rod nuts equally to 20 ft-lb torque, *NO MORE - NO LESS*, or spools may bind and stick.

## Replacing Spool Seals:

*NOTE - For the purpose of these instructions, we will consider the control handle side of the valve as the FRONT, and the opposite side the BACK.*

1. Remove control valve from the backhoe.
2. Thoroughly clean the exterior of the valve before beginning disassembly procedures.
3. At the BACK of the valve remove all bonnet assembly parts which are connected to the spool, keep parts in the order of disassembly. See Fig 9 for the parts involved in the make-up of the bonnet assembly.  
*IMPORTANT - DO NOT remove the spool from the valve. The seals can be replaced externally. Prevent spool from turning or moving by inserting a screw driver through clevis slot, or by running a rod through the pin hole and using the rod as a handle. DO NOT hold the spool with a wrench. This will destroy the finish.*
4. At the BACK of the valve, remove seal retainer, back-up washer, and spool O-ring seal, or retaining sleeve, bonnet O-ring seal, and spool U-cup seal.

5. Thoroughly clean counter-bores.

6. Install new seals:

### A. Spring-Centered Bonnet Assembly Only:

Lightly oil new O-ring seal. Slide O-ring seal over valve spool and insert in seal counter-bore. Replace back-up washer and seal retainer.

### B. Float Bonnet Assembly Only:

Replace retaining sleeve on valve spool. Lightly oil new U-cup seal. Slide U-cup seal over valve spool being careful to orient seal as shown in Fig 9. Install new O-ring seal in bonnet counter-bore.

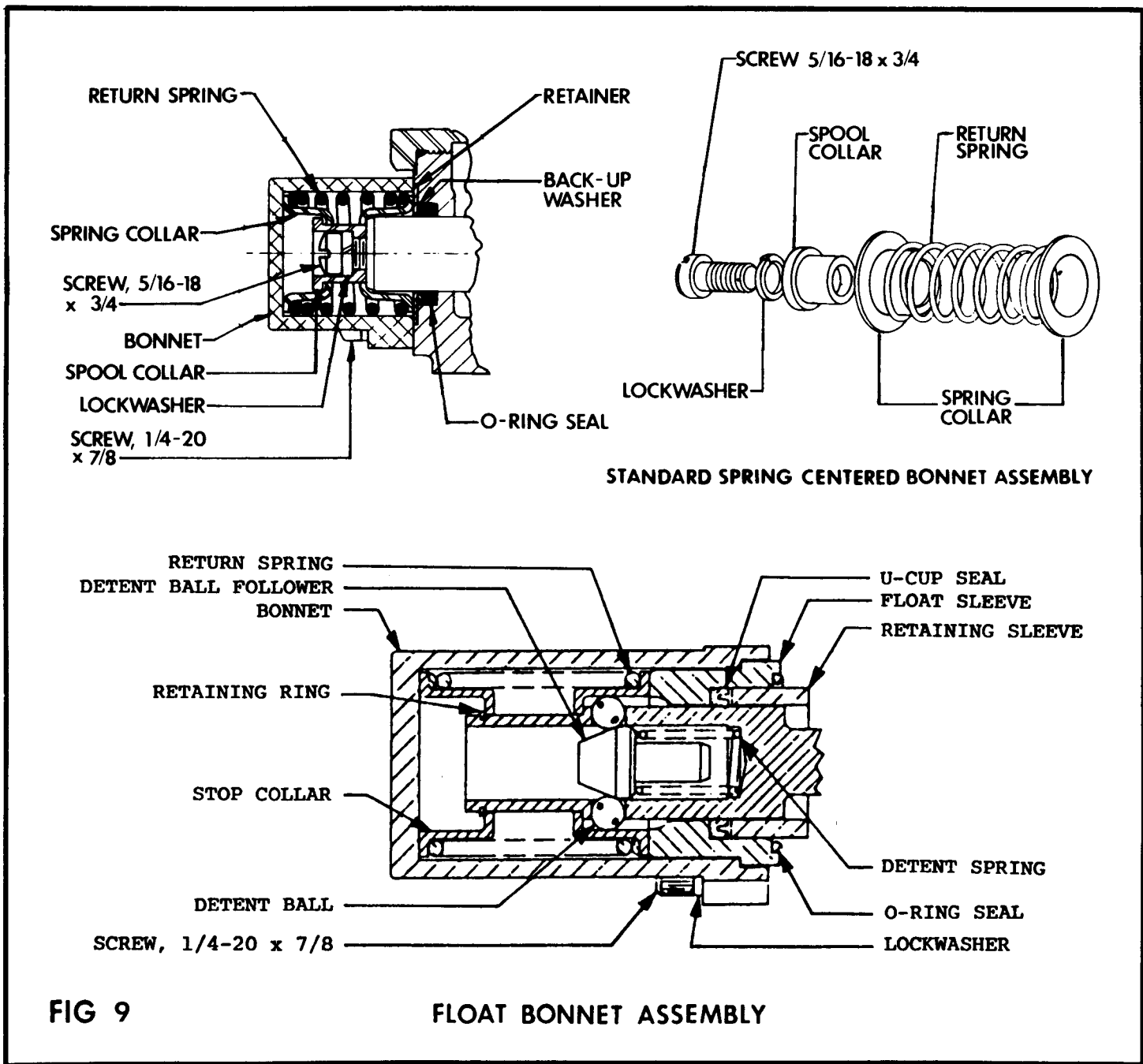

**FIG 9**

7. At the BACK of the valve replace bonnet assembly parts, reversing the order in which they were disassembled in step 3. Use 12 ft-lb torque to tighten assembly screw on spring centered bonnet assembly.

8. At the FRONT of the valve remove all parts connected to the spool (handle, linkage, etc.).

9. At the FRONT of the valve remove seal plate retainer, seal retainer, back-up washer, and spool O-ring seal.

10. Thoroughly clean counter-bore.

11. Lightly oil new O-ring seal. Slide O-ring seal over valve spool and insert in seal counter-bore. Replace back-up washer, seal retainer, and seal plate retainer.

12. Reattach all parts connected to the spool (handle, linkage, etc.).

# CONTROL VALVE SECTION

TYPICAL SECTION FOR LIFT CIRCUIT

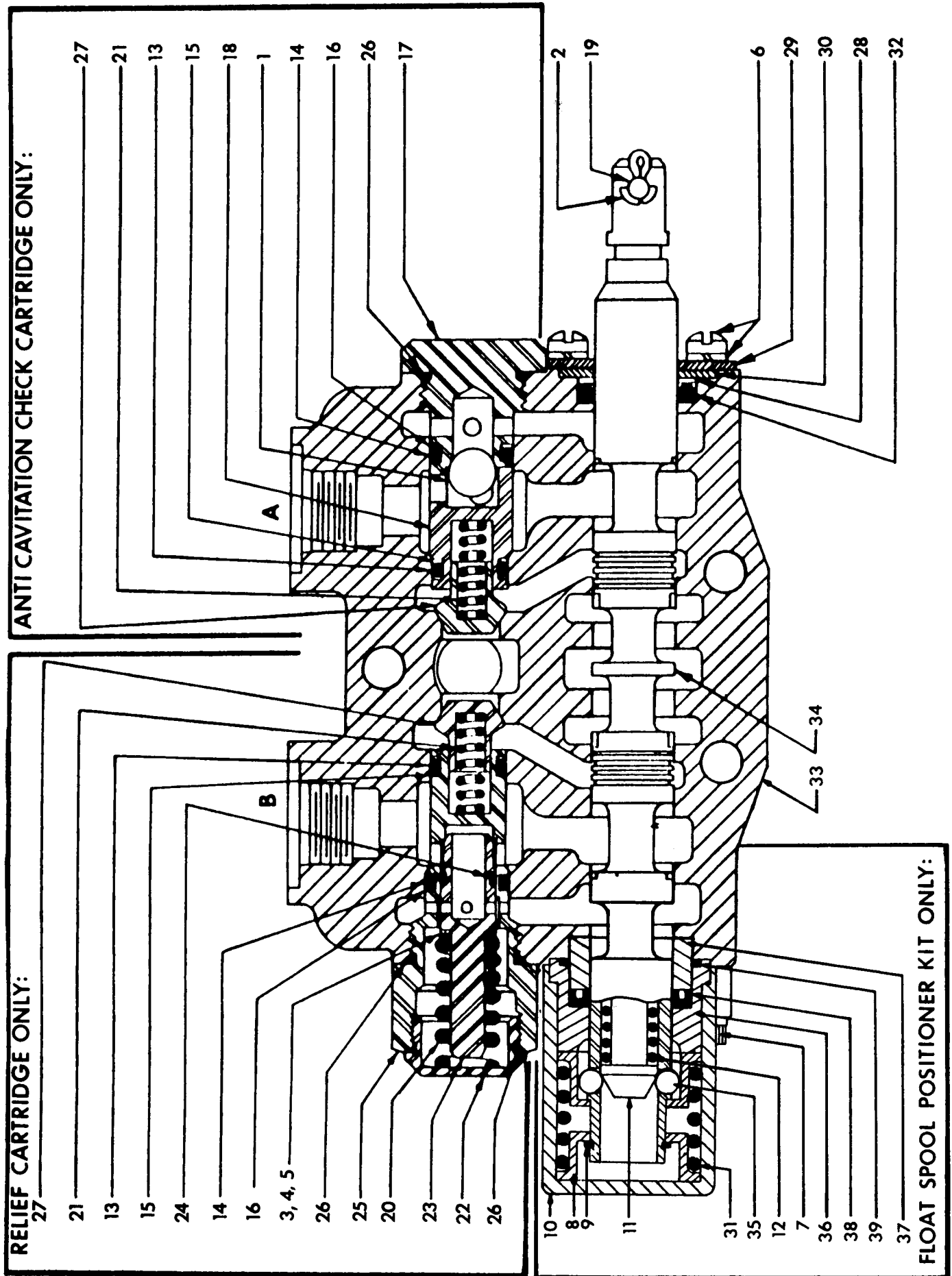

FIG 10

CONTROL VALVE SECTION - LIFT CIRCUIT

PARTS LIST - FIG 10

Index	Part No.	Description	Quantity Per Section
1	*	7/16" Steel Ball.....	1
2	8554	Handle Pin Cotter, 3/32 x 3/4.....	1
3,4,5	*	Shim, (.010", .020", .040" thick).....	as required
6	*	Machine Screw and Lockwasher.....	2
7	***	Bonnet Screw.....	2
8	***	Stop Collar.....	2
9	***	Retaining Ring.....	1
10	***	Bonnet.....	1
11	***	Detent Ball Follower.....	1
12	***	Detent spring.....	1
13	**	O-Ring Seal (Inner).....	2
14	**	O-Ring Seal (Outer).....	2
15	**	Back-Up Washer (Inner).....	4
16	**	Back-Up Washer (Outer).....	2
17	*	Anti-Cavitation Check Body.....	1
18	*	Check Ball Retainer.....	1
19	13436	Handle Clevis Pin, 1/4 dia. x 7/8.....	1
20	*	Spring (2201 - 3000 PSI Crack).....	1
21	*	Check Spring.....	2
22	*	Relief Cap.....	1
23	**	Relief Poppet.....	1
24	**	Piston Ring.....	1
25	*	Relief Body.....	1
26	**	O-Ring Seal.....	3
27	*	Steel Check.....	2
28	**	Back-Up Washer.....	2
29	*	Seal Plate Retainer.....	1
30	*	Seal Retainer.....	2
31	***	Centering Spring.....	1
32	**	Spool O-Ring Seal.....	2
33	*	Center Section Housing.....	1
34	*	Four-Way Spool.....	1
35	***	Detent Ball.....	4
36	***	Float Sleeve.....	1
37	***	Retaining Sleeve.....	1
38	**	U-Cup Seal.....	1
39	**	O-Ring Seal.....	1
10522		Control Valve Section - Lift Circuit, consisting of above listed parts. NOTE - One Orifice Plate ( <del>10312</del> ) must be added to "A" port to complete lift section. <del>10357</del> .....	1
10516		Control Valve Section Seal Kit - Lift Circuit, consisting of: 32 (Qty 1), 13 (Qty 2), 14 (Qty 2), 28 (Qty 1), 38 (Qty 1), 39 (Qty 1), 15 (Qty 4), 16 (Qty 2), 26 (Qty 2), pressure section seal (Qty 2), and exhaust section seal (Qty 2).....	1
10517		Spool Seal Kit; consisting of: 32 (Qty 1), 28 (Qty 1), 38 (Qty 1), and 39 (Qty 1).....	1
10303		Relief Cartridge (2500 PSI), as shown.....	1
10313		Relief Cartridge Seal Kit; consisting of: 13 (Qty 1), 14 (Qty 1), 15 (Qty 2), 16 (Qty 1), 26 (Qty 2)...	1
10177		Poppet Seal Kit, consisting of: 23 (Qty 1) and 24 (Qty 1)...	1
10304		Anti-Cavitation Check Cartridge, as shown.....	1
10313		Anti-Cavitation Check Seal Kit, same as Relief Cartridge Seal Kit listed above.....	1
10518		Float Spool Positioner Kit, as shown.....	1

- \* Not available as a separate repair part, order complete section or cartridge.
- \*\* Not available as a separate repair part, order seal kit.
- \*\*\* Not available as a separate repair part, order spool positioner kit.



# CONTROL VALVE SECTION

TYPICAL SECTION FOR CROWD CIRCUIT

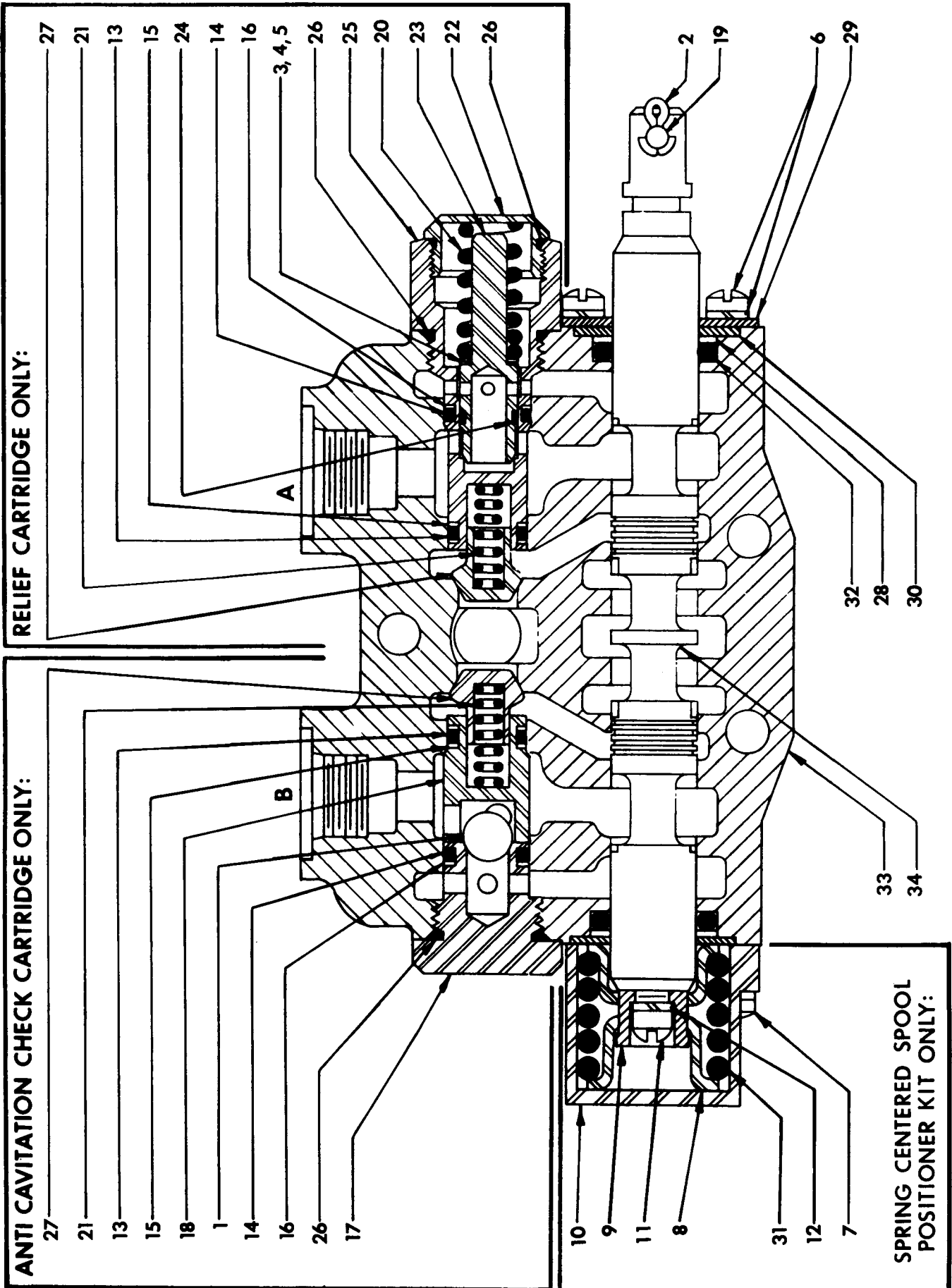

FIG 11

CONTROL VALVE SECTION - CROWD CIRCUIT

PARTS LIST - FIG 11

Index No.	Part No.	Description	Quantity Per Section
1	*	7/16" Steel Ball.....	1
2	8554	Handle Pin Cotter, 3/32 x 3/4.....	1
3	*	Shim, .040" Thick)	
4	*	Shim, .020" Thick).....	as required
5	*	Shim, .010" Thick)	
6	*	Machine Screw and Lockwasher.....	2
7	***	Bonnet Screw.....	2
8	***	Stop Collar.....	2
9	***	Spool Collar.....	1
10	***	Bonnet.....	1
11	***	Spool Assembly Screw.....	1
12	***	Spool Assembly Screw Lockwasher.....	1
13	**	O-Ring Seal (Inner).....	2
14	**	O-Ring Seal (Outer).....	2
15	**	Back-Up Washer (Inner).....	4
16	**	Back-Up Washer (Outer).....	2
17	*	Anti-Cavitation Check Body.....	1
18	*	Check Ball Retainer.....	1
19	13436	Handle Clevis Pin, 1/4 Dia x 7/8.....	1
20	*	Spring (2201 - 3000 PSI Crack).....	1
21	*	Check Spring.....	2
22	*	Relief Cap.....	1
23	**	Relief Poppet.....	1
24	**	Piston Ring.....	1
25	*	Relief Body.....	1
26	**	O-Ring Seal.....	3
27	*	Steel Check.....	2
28	**	Back-Up Washer.....	2
29	10321	Seal Plate Retainer.....	1
30	10322	Seal Retainer.....	2
31	***	Centering Spring.....	1
32	**	Spool O-Ring Seal.....	2
33	*	Center Section Housing.....	1
34	*	Four-Way Spool.....	1
	10155	Control Valve Section - Crowd Circuit, consisting of above listed parts.....	1
	10315	Control Valve Section Seal Kit - Crowd Circuit, consisting of: 32(quan-2), 13(quan-2), 14(quan-2), 15(quan-4), 16(quan-2), 26(quan-2), pressure section seal(quan-2), and exhaust section seal(quan-2).....	1
	10316	Spool Seal Kit; consisting of: 32(quan-2) and 28(quan-2).....	1
	10303	Relief Cartridge (2500 PSI), as shown.....	1
	10313	Relief Cartridge Seal Kit; consisting of: 13(quan-1), 14(quan-1), 15(quan-2), 16(quan-1), and 26(quan-2).....	1
	10177	Poppet Seal Kit, consisting of: 23(quan-1) and 24(quan-1).....	1
	10304	Anti-Cavitation Check Cartridge, as shown.....	1
	10313	Anti-Cavitation Check Seal Kit, same as Relief Cartridge Seal Kit listed above.....	1
	10107	Spring Centered Spool Positioner Kit, as shown.....	1

- \* Not available as a separate repair part, order complete section or cartridge.
- \*\* Not available as a separate repair part, order seal kit.
- \*\*\* Not available as a separate repair part, order spool positioner kit.

# CONTROL VALVE SECTION

TYPICAL SECTION FOR ACTUATE (BUCKET), SWING, AND STABILIZER CIRCUITS

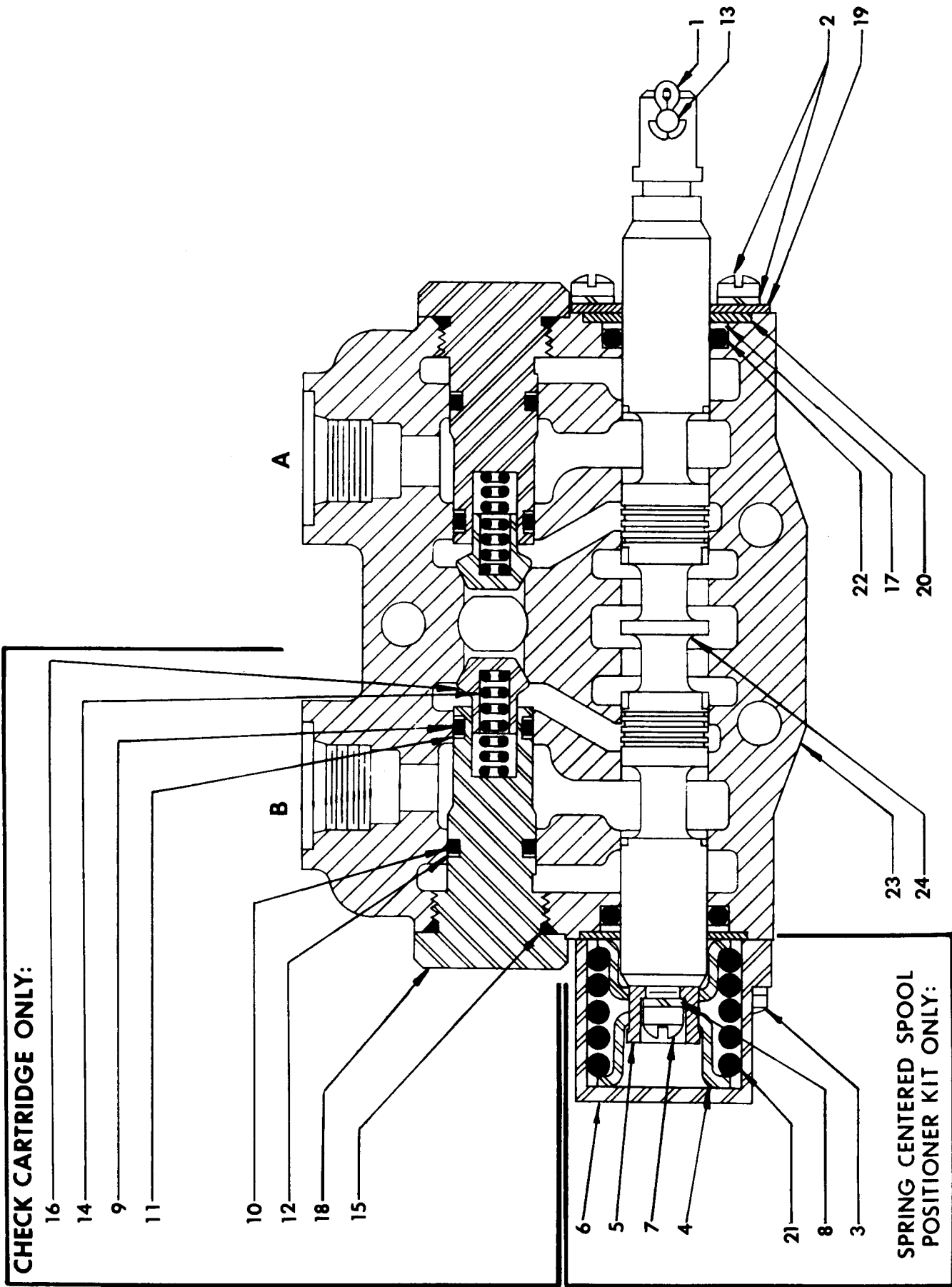

**FIG 12**

CONTROL VALVE SECTION - ACTUATE (BUCKET), SWING, AND STABILIZER CIRCUITS

PARTS LIST - FIG 12

Index No.	Part No.	Description	Quantity Per Section
1	8554	Handle Pin Cotter, 3/32 x 3/4.....	1
2	*	Machine Screw and Lockwasher.....	2
3	***	Bonnet Screw.....	2
4	***	Stop Collar.....	2
5	***	Spool Collar.....	1
6	***	Bonnet.....	1
7	***	Spool Assembly Screw.....	1
8	***	Spool Assembly Screw Lockwasher.....	1
9	**	Check Plug O-Ring Seal (Inner).....	2
10	**	Check Plug O-Ring Seal (Outer).....	2
11	**	Back-Up Washer (Inner).....	4
12	**	Back-Up Washer (Outer).....	2
13	13436	Handle Clevis Pin, 1/4 Dia x 7/8.....	1
14	*	Lift Check Spring.....	2
15	**	Lift Check Plug O-Ring Seal.....	2
16	*	Lift Check Poppet.....	2
17	**	Back-Up Washer.....	2
18	*	Lift Check Plug.....	2
19	10321	Seal Plate Retainer.....	1
20	10322	Seal Retainer.....	2
21	***	Centering Spring.....	1
22	**	Spool O-Ring Seal.....	2
23	*	Center Section Housing.....	1
24	*	Four-Way Spool.....	1
	10156	Control Valve Section - Actuate (Bucket), Swing, and Stabilizer Circuits, consisting of above listed parts.....	1
		<i>NOTE - Two Orifice Plates (10257) must be added to complete Swing Section.</i>	
	10315	Control Valve Section Seal Kit - Actuate (Bucket), Swing, and Stabilizer Circuits, consisting of: 22(quan-2), 9(quan-2), 10(quan-2), 11(quan-4), 12(quan-2), 15(quan-2), pressure section seal (quan-2), and exhaust section seal(quan-2).....	1
	10316	Spool Seal Kit; consisting of: 22(quan-2) and 17 (quan-2).....	1
	10305	Check Cartridge, as shown.....	2
	10313	Check Cartridge Seal Kit; consisting of: 9(quan-1), 10(quan-1), 11(quan-2), 12(quan-1), and 15(quan-2).....	2
	10107	Spring Centered Spool Positioner Kit, as shown.....	1

- \* Not available as a separate repair part, order complete section or cartridge.
- \*\* Not available as a separate repair part, order seal kit.
- \*\*\* Not available as a separate repair part, order spool positioner kit.

# MAIN SYSTEM RELIEF VALVE (1950 PSI)

LOCATION: LEFT HAND VALVE COVER

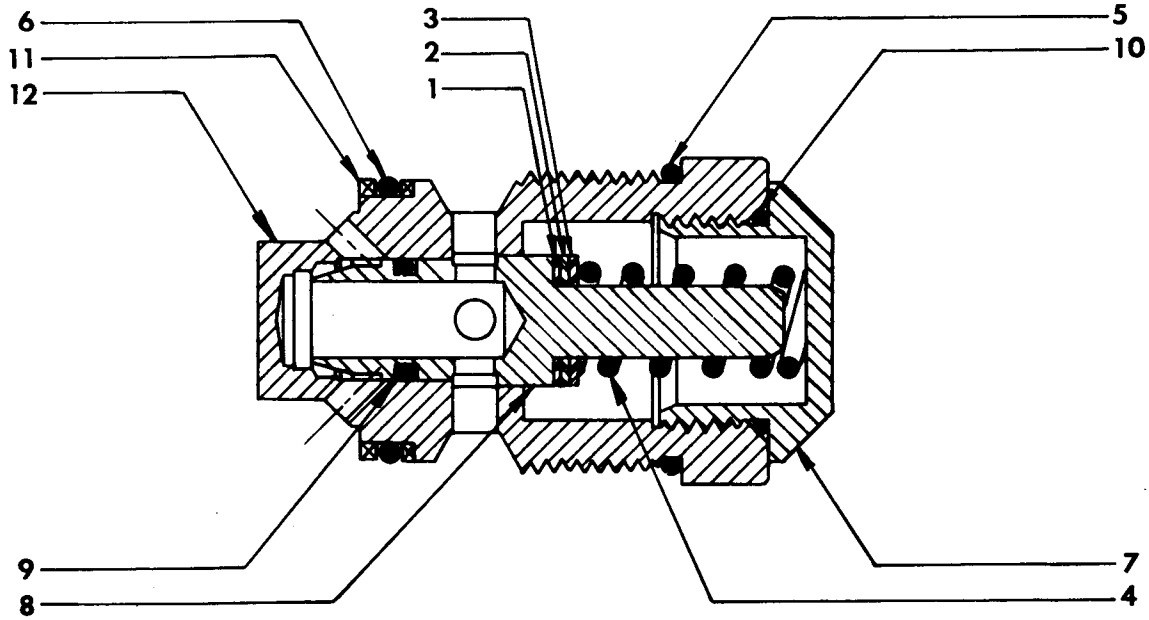

FIG 13

## MAIN SYSTEM RELIEF VALVE

### PARTS LIST - FIG 13

Index No.	Part No.	Description	Required
1	*	Shim, .040" Thick)	
2	*	Shim, .020" Thick).....	as required
3	*	Shim, .010" Thick)	
4	*	Spring (1751 - 2200 PSI Crack).....	1
5	**	O-Ring Seal.....	1
6	**	O-Ring Seal.....	1
7	*	Relief Cap.....	1
8	**	Relief Poppet.....	1
9	**	Piston Ring.....	1
10	**	O-Ring Seal.....	1
11	**	Back-Up Washer.....	2
12	*	Body.....	1
	23017	Main System Relief Valve, consisting of above listed parts.....	1
	10172	Seal and Service Kit; consisting of: 5(quan-1), 6(quan-1), 8(quan-1), 9(quan-1), 10(quan-1), and 11(quan-2).....	1

\* Not available as a separate repair part, order complete Main System Relief Valve.

\*\* Not available as a separate repair part, order Seal and Service Kit.

### ADDITIONAL REPAIR PARTS (NOT SHOWN)

Part No.	Description	Required
23018	Left Hand End Cover with Main Relief Valve.....	1
10160	Tie Rod Kit (Six-Spool) contains three Studs and three Stud Nuts.....	1
10176	Valve Seal Kit, containing all O-Rings and Back-Up Rings for a Six-Spool Valve.....	1
23016	Six-Spool Valve.....	1
10308	Right Hand End Cover.....	1
10317	Section Seal (Pressure).....	2
10318	Section Seal (Exhaust).....	2

VALVE MOUNT, CONTROLS, AND SEAT

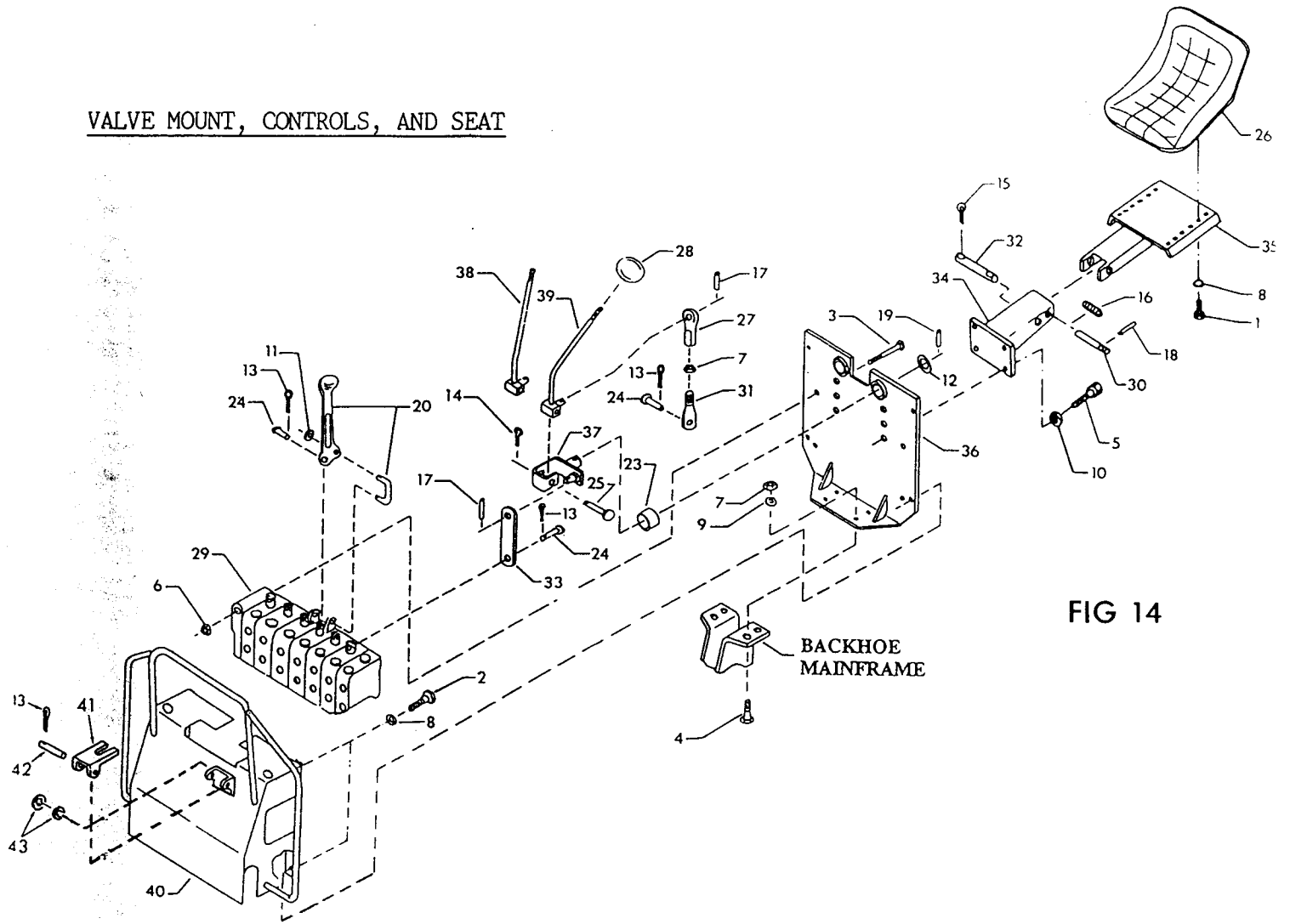

FIG 14

PARTS LIST - FIG. 14

**SERIAL NUMBER  
2524 AND LATER**

Index	Description	Part No.
1	Bolt, 5/16 NC x 3/4	6787
2	Bolt, 5/16 NF x 1	6795
3	Bolt, 5/16 NC x 2-3/4	6819
4	Bolt, 3/8 NF x 1-1/4 Gr. 8	6860
5	Bolt, 1/2 NF x 1	7012
6	Locknut, 5/16 NC	7433
7	Nut, 3/8 NF Gr. 5	7461
8	Lockwasher, 5/16	8071
9	Lockwasher, 3/8	8079
10	Lockwasher, 1/2	8101
11	Flat Washer, 3/16	8141
12	Machine Bushing, 1-1/2 OD x 1 ID x 18GA	8283
13	Cotter Pin, 3/32 x 3/4	8554
14	Cotter Pin, 5/32 x 1-1/4	8574
15	Cotter Pin, 3/16 x 1-1/4	8582
16	Spring	8711
17	Roll Pin, 5/32 x 3/4	8953
18	Roll Pin, 3/16 x 2	8978

Index	Description	Part No.
19	Roll Pin, 3/8 x 1-3/4	9018
20	Stabilizer Handle Complete	10144
23	Bronze Bushing, 1-1/4 OD x 1 ID x 1	11993
24	Clevis Pin, 1/4 Dia x 7/8	13436
25	Clevis Pin, 1/2 Dia x 2-1/4	13454
26	Seat	13919
27	Ball Joint, 3/8 NF Female	14029
28	Round Knob, 1/2 NC	14058
29	Control Valve	23016
30	Slide Pin	851988
31	Handle Link	856226
32	Pin, 5/8 Dia x 5-5/8	856256
33	Link	856451
34	Seat Bracket Assembly	860135
35	Seat Plate Weldment	856475
36	Valve Plate, with Bushings	857955
37	Linkage Pivot Weldment	857960
38	R.H. Control Handle	857965
39	L.H. Control Handle	857970
40	Valve Shroud	860195
41	Latch Plate	859336
42	Pin	859338
43	Flat Washer, 5/16 SAE	8152

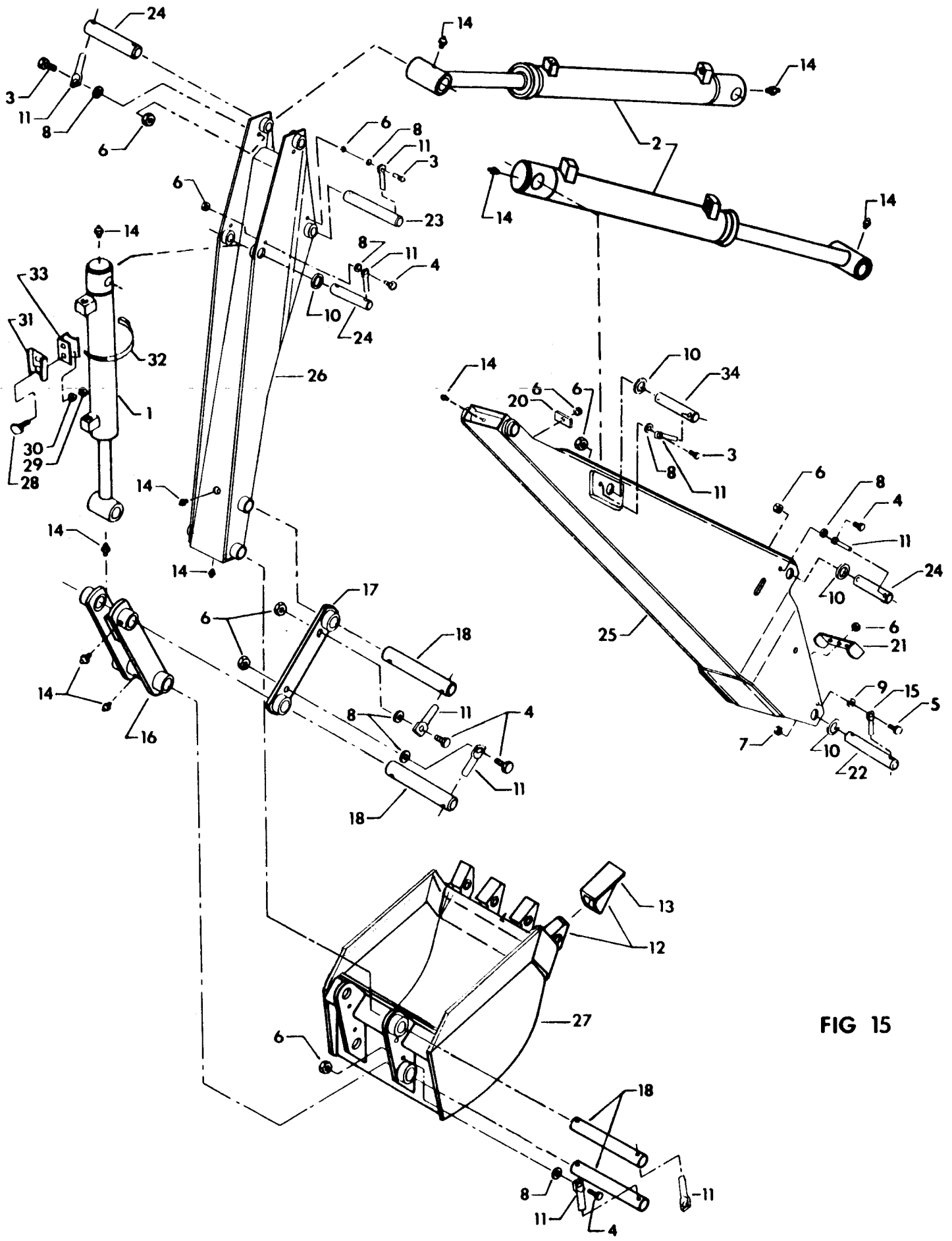

FIG 15



PARTS LIST - FIG 15

Index	Description	Part No.	Index	Description	Part No.
1	Hydraulic Cylinder-Bucket.....	083	20	Hose Retainer.....	856233
2	Hydraulic Cylinder- Boom/Dipperstick.....	091	21	Hose Strap.....	856237
3	Bolt, 5/16 NF x 3/4.....	6789	22	Pin, 1" Dia. x 8-3/16.....	856241
4	Bolt, 5/16 NF x 7/8.....	6790	23	Pin, 1" Dia. x 6-7/8.....	856242
5	Bolt, 3/8 NF x 1".....	6851	24	Pin, 1" Dia. x 5-5/8.....	856243
6	Locknut, 5/16 NF.....	7437	25	Boom Weldment.....	860045
7	Locknut, 3/8 NF.....	7466	26	Dipperstick Weldment.....	860060
8	Flat Washer, 5/16 SAE.....	8152	27	Bucket Complete - 9 inch....	W215
9	Flat Washer, 3/8 SAE.....	8158	27	Bucket Complete - 13 inch....	W216
10	Machine Bushing, 1-1/2 OD x 1" ID x 18 GA.....	8283	27	Bucket Complete - 16 inch....	W217
11	Retainer, 5/16.....	13473	27	Bucket Complete - 19 inch....	W218
12	Bucket Tooth and Shank.....	13613	27	Bucket Complete - 24 inch....	W219
13	Bucket Tooth Only.....	13617	27	Bucket Complete - 36 inch....	W208
14	Grease Fitting.....	14505	28	Carriage Bolt, 5/16 NC x 3/4.....	6574
15	Pin Retainer - Small.....	13474	29	Nut, 5/16 NC.....	7431
16	Bucket Link Weldment.....	855120	30	Lockwasher, 5/16.....	8071
17	Guide Link Weldment.....	856220	31	SMV Socket.....	13683
18	Pin, 1" Dia. x 7-3/8.....	855151	32	Hose Clamp.....	14140
			33	SMV Socket Mount.....	857921
			34	Pin, 1" Dia. x 6".....	860087

### TORQUE VALUES

Common bolts and nuts.

Tightening Torque ± 20%

SIZE	GRADE 2 	GRADE 5 	GRADE 8 
1/4-20 NC	70 in lb	115 in lb	165 in lb
1/4-28 NF	85 in lb	140 in lb	200 in lb
5/16-18 NC	150 in lb	250 in lb	350 in lb
5/16-24 NF	165 in lb	270 in lb	30 ft lb
3/8-16 NC	260 in lb	35 ft lb	50 ft lb
3/8-24 NF	300 in lb	40 ft lb	60 ft lb
7/16-14 NC	35 ft lb	55 ft lb	80 ft lb
7/16-20 NF	45 ft lb	75 ft lb	105 ft lb
1/2-13 NC	50 ft lb	80 ft lb	115 ft lb
1/2-20 NF	70 ft lb	105 ft lb	165 ft lb
9/16-12 NC	75 ft lb	125 ft lb	175 ft lb
9/16-18 NF	100 ft lb	165 ft lb	230 ft lb
5/8-11 NC	110 ft lb	180 ft lb	260 ft lb
5/8-18 NF	140 ft lb	230 ft lb	330 ft lb
3/4-10 NC	150 ft lb	245 ft lb	350 ft lb
3/4-16 NF	200 ft lb	325 ft lb	470 ft lb

NOTE - See tractor instruction manual or your tractor dealer for tightening of metric bolts.



PARTS LIST - FIG 16

Index	Description	Part No.	Index	Description	Part No.
38	Hydraulic Cylinder - Swing.....	158	48	Quick Release Pin - Long.....	13495
39	Bolt, 5/16 NF x 1".....	6795	49	Grease Fitting.....	14505
40	Bolt, 5/16 NF x 1-1/4.....	6799	50	Pin Retainer - Small.....	13474
41	Bolt, 3/8 NF x 1".....	6851	51	Thrust Washer.....	855171
42	Locknut, 5/16 NF.....	7437	52	Swing Frame Assembly (includes items 47 & 60)...	860040
43	Lockwasher, 3/8.....	8079	53	Swing Link Weldment.....	856190
44	Machine Bushing, 1-1/2 OD x 1" ID x 18 GA.....	8283	55	Hose Retainer.....	856233
45	Cotter Pin, 1/4 x 1-1/2.....	8602	56	Hose Bracket.....	856236
46	Cotter Pin, 5/16 x 2-1/2.....	8614	57	Hose Strap.....	856237
47	Bronze Bearing, 1-1/4 OD x 1" ID x 1".....	11993	58	Pin, 1" Diameter x 5-1/2.....	856244
			59	Pin, 1" Diameter x 4-1/8.....	856248
			60	Bronze Bushing, 1-3/4 OD x 1-1/2 ID x 1".....	11994

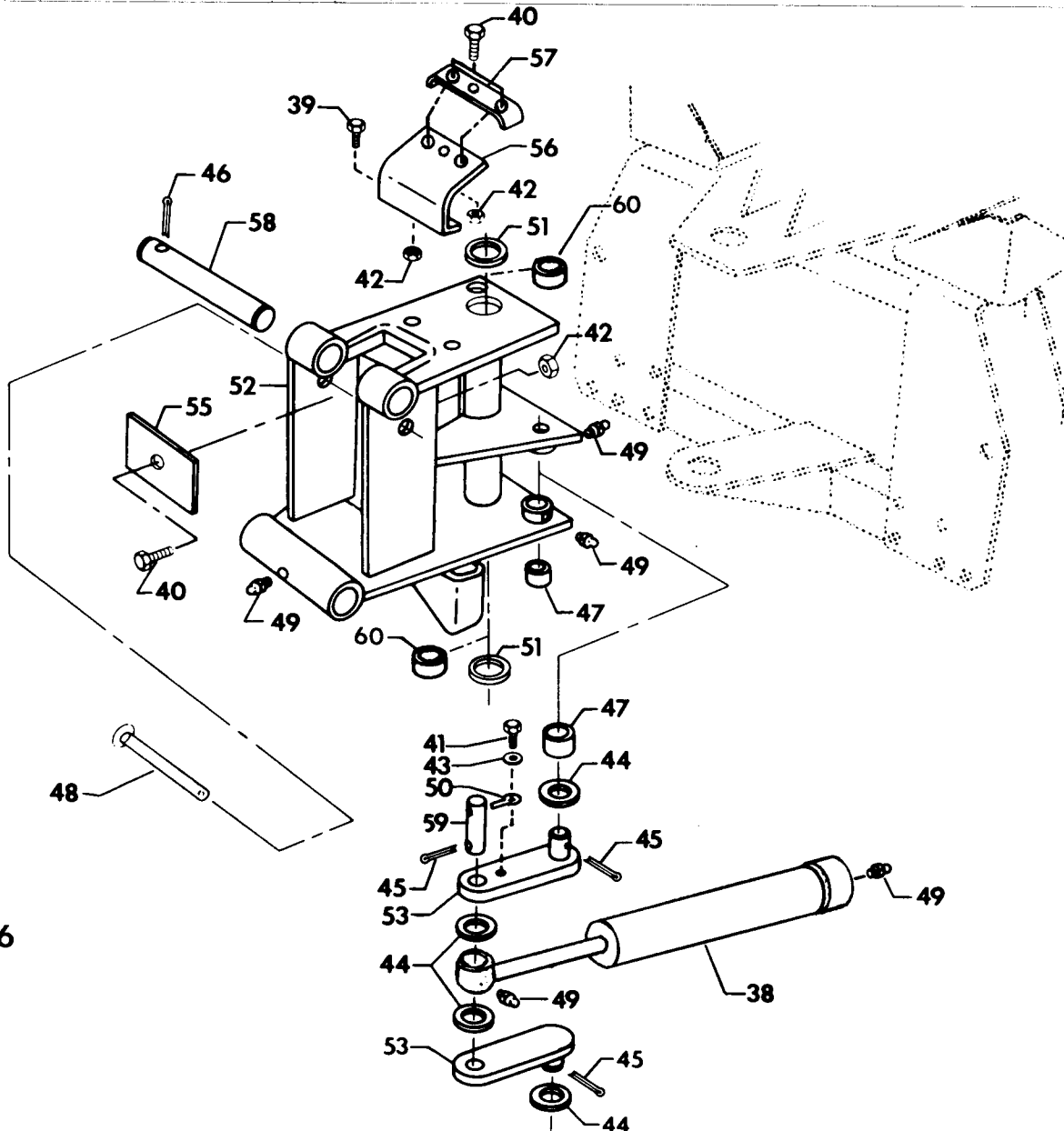

FIG 16

**SERIAL NUMBER 2524 AND LATER**

**PARTS LIST - FIG 17**

<u>Index</u>	<u>Description</u>	<u>Part No.</u>
--------------	--------------------	-----------------

77	Hydraulic Cylinder - Stabilizer.....	073
78	Bolt, 5/16 NF x 1-1/4.....	6799
79	Bolt, 1/2 NF x 1".....	7012
82	Lockwasher, 5/16.....	8071
83	Lockwasher, 1/2 Shakeproof..	8103
85	Flat Washer, 5/16.....	8151
86	Flat Washer, 1/2 SAE.....	8173
87	Flat Washer, 5/8 SAE.....	8183
88	Machine Bushing, 2-1/4 OD x 1-1/2 ID x 16 GA.....	8232
90	Cotter Pin, 3/16 x 1-1/4....	8582
91	Cotter Pin, 1/4 x 1-1/2....	8602
93	Foot Pad - Large.....	12906
94	Foot Pad - Small.....	12907
95	Quick Release Pin-Short....	13492
96	Bumper.....	13681
97	Grease Fitting.....	14505
98	Pin Retainer - Large.....	851123
99	Stabilizer Claw.....	12483
100	Pin, 1" Diameter x 4-1/4..	855147
101	Pin, 5/8 Dia. x 4-15/16...	855174
102	Mainframe Weldment.....	856115
103	Stabilizer Weldment.....	860075
105	Stabilizer Shield.....	859385
106	Main Pivot Shaft.....	856238
107	Pin, 5/8 Dia. x 5-5/8.....	856256
108	Pin, 5/8 Dia. x 3-7/8.....	856247
109	Pin, 5/8 Dia. x 5-5/8.....	860086
110	Grease Fitting, 45°.....	14521
111	Bolt, 5/16 NF x 7/8 Gr.5....	6790
112	Locknut, 5/16 NF.....	7437
113	Pin Retainer-Small.....	13473

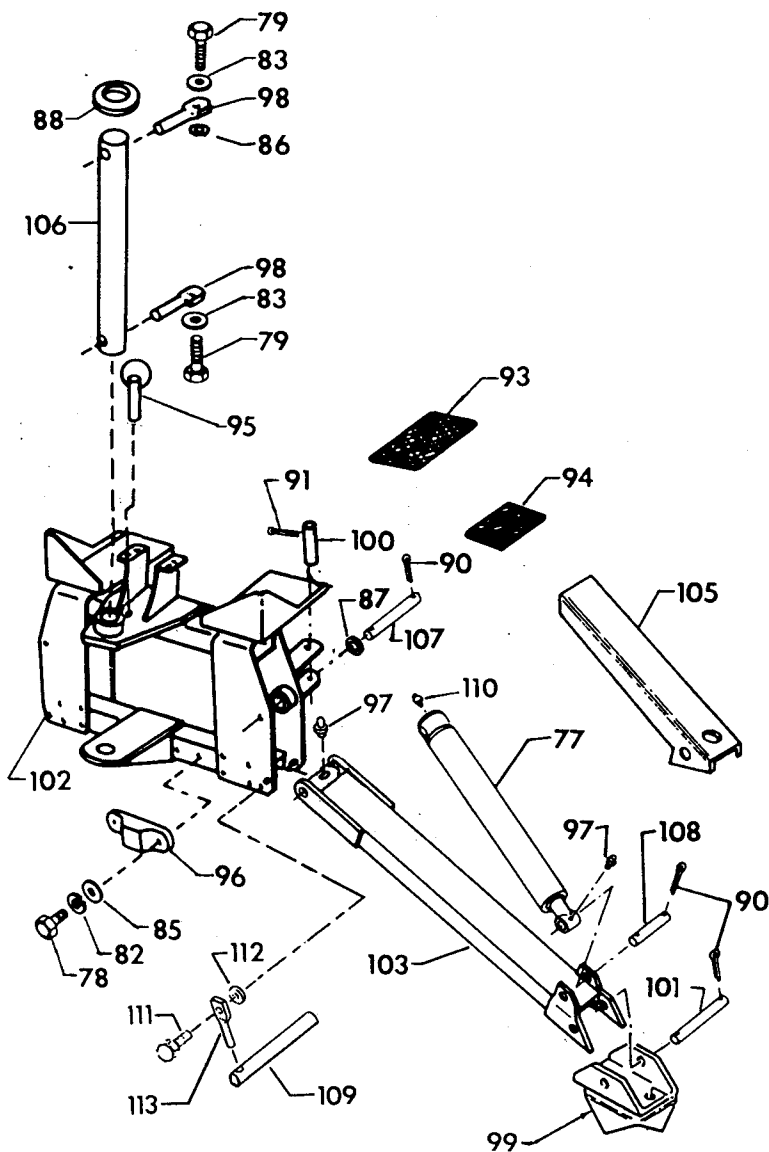
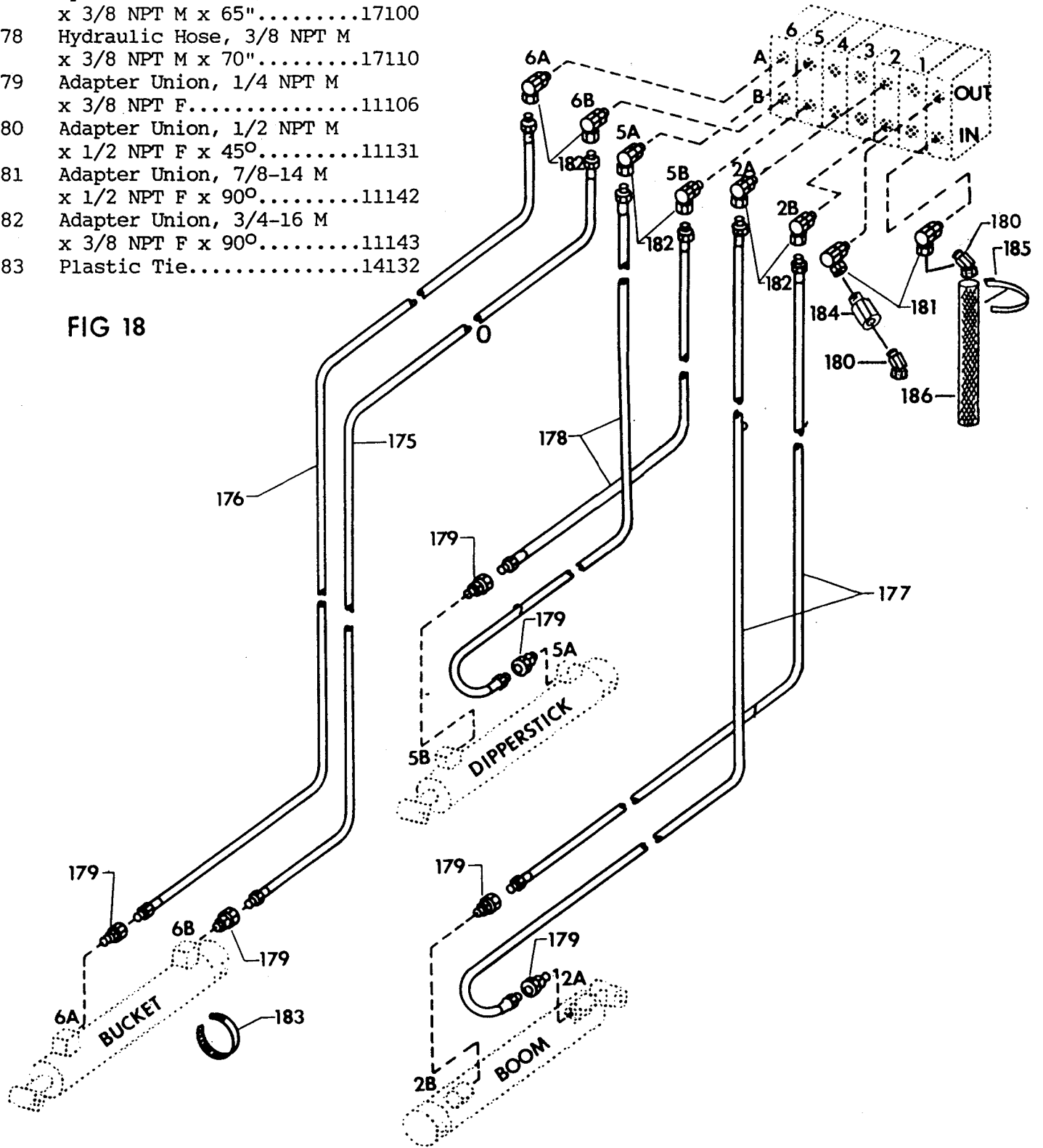

**FIG 17**

PARTS LIST - FIG 18

Index	Description	Part No.	Index	Description	Part No.
175	Hydraulic Hose, 3/8 NPT M x 3/8 NPT M x 100".....	17200	184	Check Valve.....	10166
176	Hydraulic Hose, 3/8 NPT M x 3/8 NPT M x 118".....	17220	185	Plastic Tie.....	14121
177	Hydraulic Hose, 3/8 NPT M x 3/8 NPT M x 65".....	17100	186	Hose Sleeve, 1-9/16 ID x 18".....	14127
178	Hydraulic Hose, 3/8 NPT M x 3/8 NPT M x 70".....	17110			
179	Adapter Union, 1/4 NPT M x 3/8 NPT F.....	11106			
180	Adapter Union, 1/2 NPT M x 1/2 NPT F x 45°.....	11131			
181	Adapter Union, 7/8-14 M x 1/2 NPT F x 90°.....	11142			
182	Adapter Union, 3/4-16 M x 3/8 NPT F x 90°.....	11143			
183	Plastic Tie.....	14132			

FIG 18



PARTS LIST - FIG 19

Index	Description	Part No.	Index	Description	Part No.
197	Bolt, 5/16 NC x 2-1/2.....	6813	204	Adapter Union, 1/4 NPT M x 3/8 NPT F.....	11106
198	Nut, 5/16 NC.....	7431	205	Adapter Union, 1/4 NPT M x 3/8 NPT F x 90°.....	11126
199	Hydraulic Street Elbow, 3/8 NPT x 90°.....	11179	206	Adapter Union, 3/4-16 M x 3/8 NPT F x 90°.....	11143
200	Lockwasher, 5/16.....	8071	207	Plastic Tie.....	14132
201	Cross-Over Relief, 1300 psi.....	10527	208	Hydraulic Hose, 3/8 NPT M x 3/8 NPT M x 20".....	17015
202	Hydraulic Hose, 3/8 NPT M x 3/8 NPT M x 20".....	17015	209	Plastic Tie.....	14133
203	Hydraulic Hose, 3/8 NPT M x 3/8 NPT M x 45".....	17045			

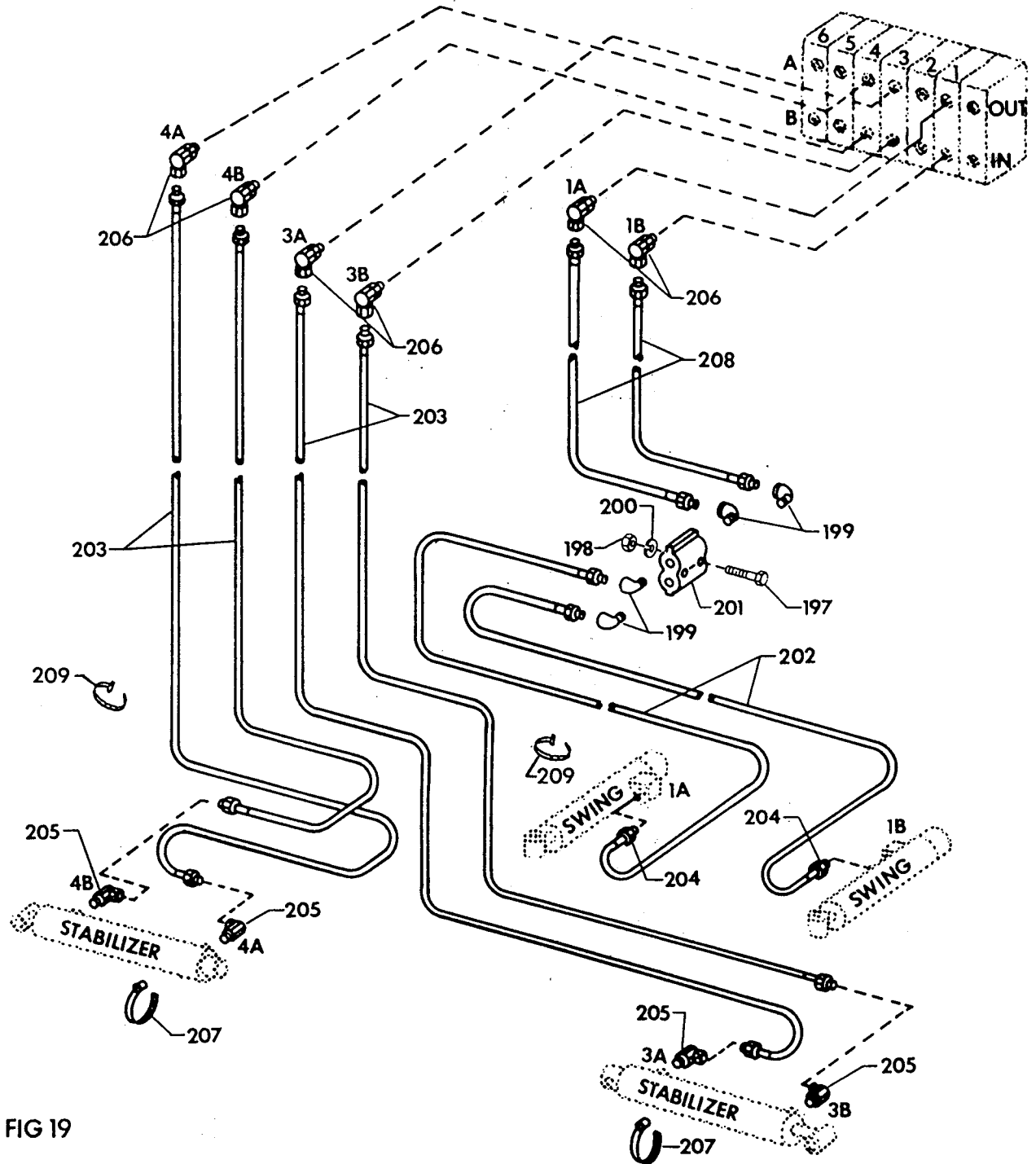
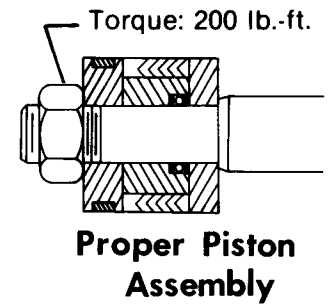
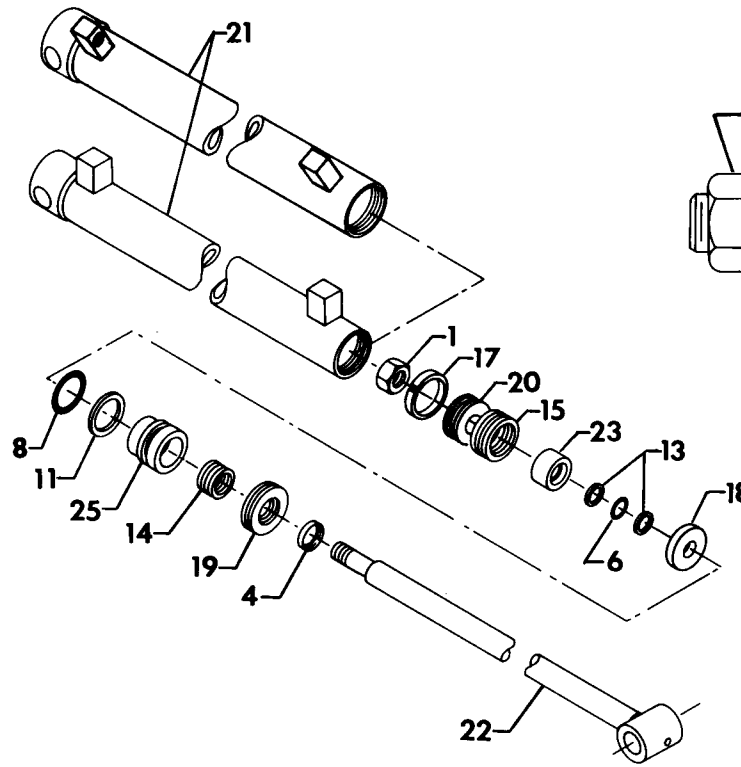

FIG 19

**091 Cylinder**  
Lift and Crowd

**083 Cylinder**  
Bucket



**073 Cylinder**  
Stabilizer

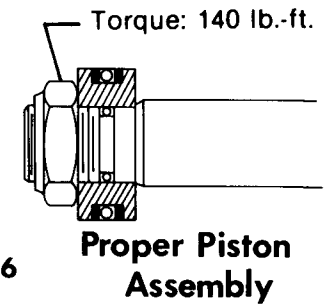
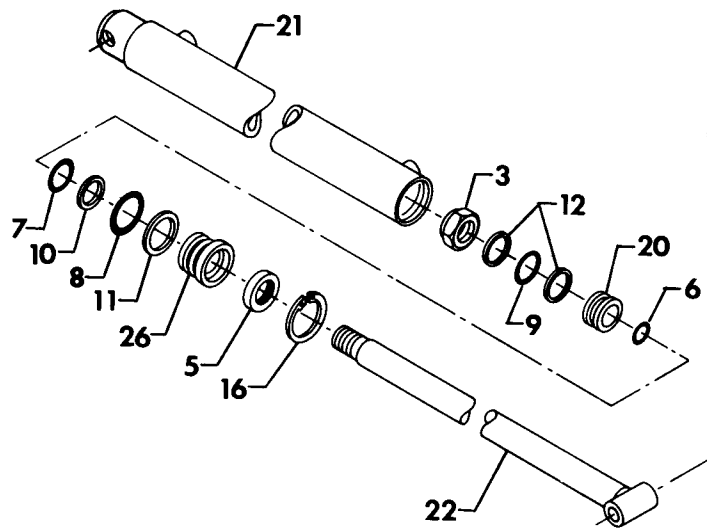

**158 Cylinder**  
Swing

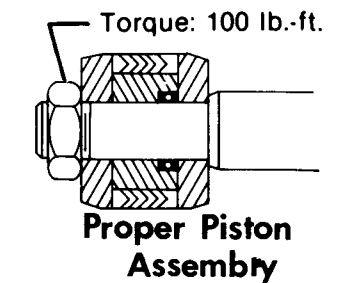
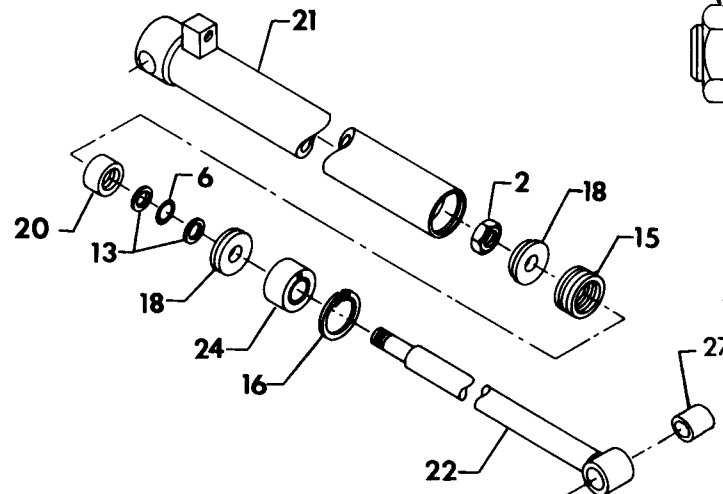

# HYDRAULIC CYLINDERS - PARTS LISTS

Index	Description	091:	083:	073:	158:
1	Lock Nut, 3/4 NF Nyloc.....	7574	7574		
2	Jam Nut, 3/4 NF Nyloc.....				7679
3	Jam Nut, 1" NF Nyloc.....			7712	
4	Oil Seal, 1-1/4 OD x 1" ID.....	*	*		
5	Oil Seal, 1-5/8 OD x 1-1/8 ID.....			*	
6	O-Ring, 1" OD x 3/4 ID.....	*	*	*	*
7	O-Ring, 1-3/8 OD x 1-1/8 ID.....			*	
8	O-Ring, 2" OD x 1-3/4 ID.....	*	*	*	
9	O-Ring, 2" OD x 1-5/8 ID.....			*	
10	Back-Up Ring, 1-3/8 OD x 1-1/8 ID.....			*	
11	Back-Up Ring, 2" OD x 1-3/4 ID.....	*	*	*	
12	Back-Up Ring, 2" OD x 1-5/8 ID.....			*	
13	Back-Up Ring, 1" OD x 3/4 ID.....	*	*		*
14	Packing Assembly, 1-3/8 OD x 1" ID.....	*	*		
15	Packing Assembly, 2" OD x 1-1/2 ID.....	*	*		*
16	Retaining Ring, Internal.....			*	13406
17	Wear Ring, 2" OD x 1-3/4 ID x 3/8.....	*	*		
18	Piston Washer.....	904467	904467		904052
19	Gland Nut.....	904053	904053		
20	Piston.....	904466	904466	904231	904567
21	Cylinder Tube Weldment.....	904550	904450	904365	904565
22	Piston Rod Weldment.....	904560	904460	904375	904680
23	Piston Spacer, with O-Ring and Back-Ups.....	904430	904430		
24	Rod Guide Assembly.....				904445
25	Gland, with O-Ring, Back-Up, and Packing.....	904540	904540		
26	Gland.....			904232	
27	Bronze Bushing, 1" ID x 1-1/4 OD x 1-1/2.....				11990
	For Complete Cylinder, order.....	091	083	073	158
	Seal Repair Kit (includes all Packings, Wear Rings, O-Rings, Back-Up Rings, and Wipers for one cylinder).....	904485	904485	904260	904575

\* Not available as a separate repair part - order seal repair kit.

**IMPORTANT:** Replace Cylinder Nut (1, 2, or 3) any time nut must be removed, and torque to value shown on page 36.

# SPECIFICATIONS

## General Data:

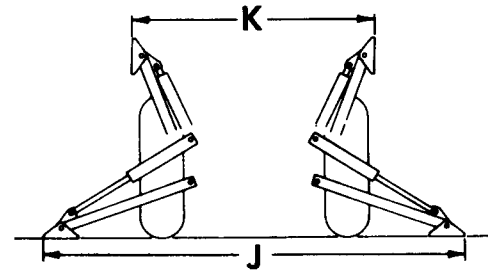
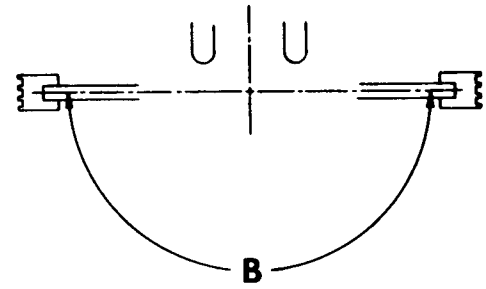
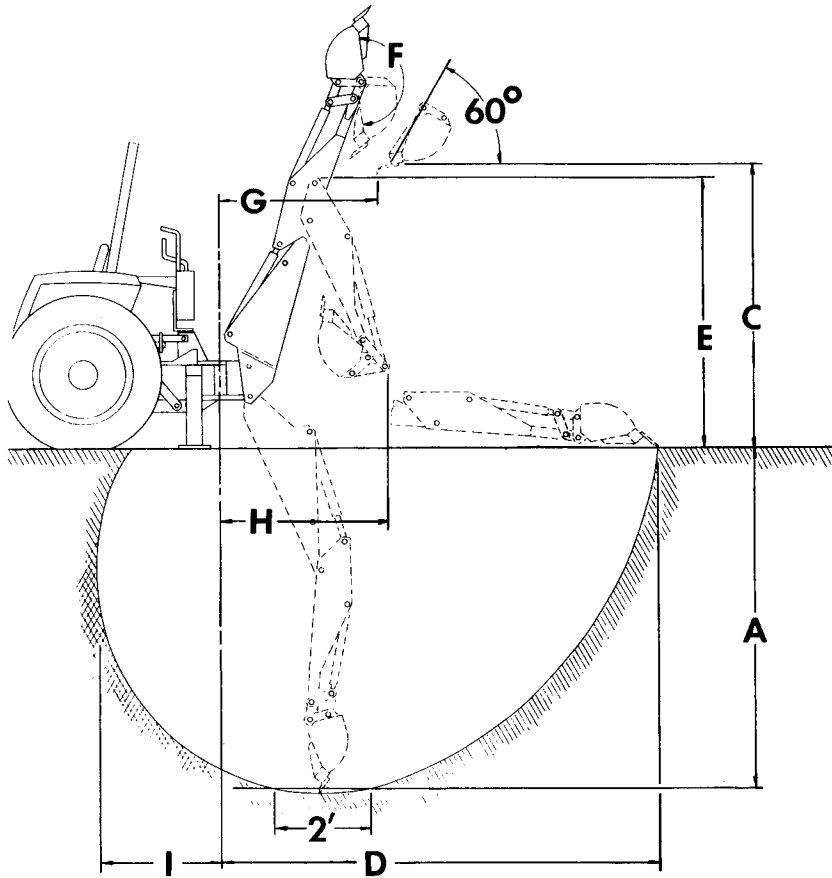

- A. Digging Depth.....7' 6"  
(two foot flat bottom)
- B. Swing Arc.....180°
- C. Loading Height.....5' 10"  
(bucket at 60°)
- D. Reach from Center Line of  
Swing Pivot.....9' 6"
- E. Transport Height (maximum).....5' 9"
- F. Bucket Rotation.....180°
- G. Loading Reach.....3' 7"  
(bucket at 60°)
- H. Transport Overhang.....3' 6"
- I. Undercut.....2' 6"

- J. Stabilizer Spread,  
down position.....7' 1"

- K. Stabilizer Spread,  
up position.....5' 1"

Bucket Cylinder  
Digging Force.....2400 lbs.

Dipperstick Cylinder  
Digging Force.....1350 lbs.

Shipping Weight  
(less bucket).....720 lbs.

Hydraulic Volume  
Requirements.....4 to 5 GPM

Hydraulic Pressure  
Requirements.....1950 psi

# SPECIFICATIONS

## Bucket Data:

BUCKET	WIDTH	SAE STRUCK CAPACITY	HEAPED CAPACITY	SHIPPING WEIGHT
W215	9 in. (230MM)	0.50 cu. ft. (.014M <sup>3</sup> )	0.63 cu. ft. (.018M <sup>3</sup> )	46 lbs. (20.9 kg)
W216	13 in. (330MM)	0.75 cu. ft. (.021M <sup>3</sup> )	1.00 cu. ft. (.028M <sup>3</sup> )	52 lbs. (23.6 kg)
W217	16 in. (405MM)	0.94 cu. ft. (.027M <sup>3</sup> )	1.25 cu. ft. (.035M <sup>3</sup> )	57 lbs. (25.6 kg)
W218	19 in. (480MM)	1.13 cu. ft. (.032M <sup>3</sup> )	1.50 cu. ft. (.042M <sup>3</sup> )	64 lbs. (29 kg)
W219	24 in. (610MM)	1.44 cu. ft. (.041M <sup>3</sup> )	2.00 cu. ft. (.057M <sup>3</sup> )	75 lbs. (34 kg)
W208	36 in. (915MM)	2.19 cu. ft. (.062M <sup>3</sup> )	3.01 cu. ft. (.085M <sup>3</sup> )	98 lbs. (44 kg)

## Cylinder Data:

CYLINDER	PISTON DIA.	STROKE	RETRACTED LENGTH	EXTENDED LENGTH	ROD DIA.	PIVOT PIN DIA.	TYPE OF ACTION
*091 - BOOM	2 (50MM)	18-1/2 (470MM)	26-3/4 (680MM)	45-1/4 (1150MM)	1 (25MM)	1 (25MM)	DA
*091 - DIPPERSTICK	2 (50MM)	18-1/2 (470MM)	26-3/4 (680MM)	45-1/4 (1150MM)	1 (25MM)	1 (25MM)	DA
083 - BUCKET	2 (50MM)	13-1/8 (333MM)	20-5/8 (524MM)	33-3/4 (857MM)	1 (25MM)	1 (25MM)	DA
073 - STABILIZER	2 (50MM)	11-1/4 (286MM)	17 (432MM)	28-1/4 (718MM)	1-1/8 (28MM)	5/8 (16MM)	DA
158 - SWING	2 (50MM)	9-7/8 (251MM)	17-3/16 (437MM)	27-1/16 (687MM)	1 (25MM)	1 (25MM)	SA

\* Identical cylinders used for both functions.



# PURCHASE AND SERVICE RECORD ---



**be careful.....  
avoid accidents**